



AIMCO Manufacturing

American Industrial Manipulator Company



PRODUCT LINE

About Our Company

AIMCO Manufacturing is a leading manufacturer of material handling equipment including articulated jib cranes, industrial manipulators, machine loading systems and custom end effectors.

Our engineers and production staff work hard every day to develop and produce the finest industrial lift assist systems available.

AIMCO was established in 1993. Our products are manufactured and assembled in our ISO 9001:2008 certified 100,000 square foot facility in Toledo, Ohio.

AIMCO is one of five companies employee owned and operated by the  RAKA CORPORATION.



203 Matzinger Road Toledo, OH 43612
Phone: (419) 478-4851 Fax: (419) 476-1324
www.AimcoManufacturing.com
Sales@AimcoManufacturing.com

▲ Table of Contents ▲

■ Suspension

Articulated Jib Overview.....	1
Articulated Jib + Torque Arm.....	3
Articulated Jib + Rigid Carriage Lift.....	5
Articulated Jib + Air Balancer (Numo Arm).....	7
Articulated VacuJib.....	9
Articulated Jib Accessories.....	11
Optional Jib Mounts.....	12

■ Lifting

Torque Arm.....	13
Rigid Carriage Lifters.....	15
Articulated Lifting Arm.....	17
Pos-A-Lift.....	19
Torque Reaction Arm.....	20
Optional Lifters/Mounts.....	21

■ Tooling

Mechanical Grab.....	23
Vacuum Grab.....	25
Magnetic Grab.....	27
Non-Powered Mechanical Grab.....	29
Manipulation.....	31

■ Controls & Safeties

Air Logic.....	33
Ergo Handles.....	34
Vertical Control Options.....	35
System Safeties.....	36
ACU Controls.....	37

■ Appendix

Articulated Jib Size and Capacity.....	A
VacuJib Size and Capacity.....	B
Portable Bases.....	C
Torque-Arm Size.....	D
How to Order: VacuJib Series.....	E
How to Order: ACU Series	F



AIM6111 with a clevis mount
mounted to a pedestal

**See Appendix A for Technical Data*

The AIMCO Advantage:

- Increased Productivity
- Ease of Movement & Positioning
- Enhanced Operator Safety
- Reduced Operator Fatigue
- Improved Work Force Utilization
- Protection of Delicate Payloads
- Reduced Work Place Injuries
- Increased Profits

AIMCO Articulated Jib cranes are widely considered the finest available. The AIMCO bearing design assures effortless and smooth rotation allowing loads to be moved freely throughout the entire work circle. Air or electrical lines are internal to the arms with rotating swivels or collector rings to maintain a continuous 360° rotation at each pivot location. Capacities range from 80 lbs. to 1,625 lbs. with radial reaches up to 15 feet. Each rotation joint is equipped with Timken tapered roller bearings, pre-greased and sealed providing a 5:1 safety factor. The end of the arm can accommodate a wide range of *hoists, balancers, rigid-lifters, end effectors, and tool-plates*. AIMCO provides standard and custom end tooling with Articulated Jib Cranes, Torque Arms and other material handling equipment creating a complete, industrial lift assist system.

AIMCO Manufacturing can customize to suit your application

Integration Options:

- Air Hoist
- Electric Hoist
- Air Balancer
- Intelligent Lifting Device (ILD)
- Hand Chain Hoist



AIM6099 with an ILD + floor mounted pedestal + custom end effector



AIM5938 with a chain hoist + pedestal + portable base and custom end effector

The Cut of Our Jib:

The AIMCO Articulated Jib can be integrated with a myriad of equipment. Our candid ability to recommend the right solution for your application is often referred to as the Cut of Our Jib. The articulated jib crane is the paragon of this philosophy; accepting everything from hand chain hoists to world-class ILD's.

Our Articulated Jib Cranes integrate with several other lifting devices

SUSPENSION





Features:

- Off-Center Load Compensation
- Reach-in, around and under obstructions
- Manipulation of loads for precise positioning
- Tilt & Rotate while retaining part orientation
- Powered with plant air
- Diverse control packages & safeties

The AIMCO torque arm bridges the gap between a hoist and a manipulator. The torque arm provides a rigid "load arm" between the work piece and the crane, allowing off-center loads to be securely transported and manipulated without a loss of required product orientation. Reach-in applications are accomplished in a safe, easy, and ergonomic manner.

AIM5738 with a floor mounted pedestal
+ custom end effector

See Appendix B for Technical Specifications

Mounting an AIMCO Torque Arm to an Articulated Jib Crane creates a very efficient and cost effective method for handling difficult loads requiring manipulation or reach-in. A few work cell examples include Machining Centers, Loading Docks, Presses, and Paint Lines.

***AIMCO Manufacturing can increase your
company's productivity by decreasing cycle times***

Rigid Lift Advantage:

- Consistent Part Orientation
- Easy Machine Loading
- Easy Machine Unloading
- Effortless Part Engagement
- No Seesaw Effect
- No List Angle Variation
- Eliminates Polygon Effect
- Requires Only One Operator
- Stable Part Removal



AIM6122
with a floor mounted pedestal + custom end effector

SUSPENSION

AIMCO's "State-of-the-art" machine loading systems offer operator safety and flexibility when performing difficult machine loading and product manipulation.

Machine loading systems handle tools, parts, blanks, and raw materials around delicate machinery. Protect your capital equipment. Protect your workforce.

Most AIMCO machine loading applications demand an AIMCO Articulated Jib Crane with a Torque Arm and End Effector or an AIMCO Articulated Lifting Arm with End Effector.

A final recommendation will be determined by factors such as desired floor coverage, maximum part weight, jib arm reach-out, end tool reach-out, and machine opening clearances. AIMCO customer service representatives and systems engineers are available for assistance.

Instead of having a box full of tools, why not incorporate your tools on the jib crane? See page -11- for Jib Crane Accessories



Features:

- Moment Load Capacity Up to 750 ft-lbs
- Vertical Lift up to 10 feet
- Flexible Lifting Device Integration
- Continuous 360° rotation about vertical axis

AIMCO's "Rigid Column Lift" (RCL) is a rigid lifting system that provides maximum lift in work areas where headroom is a premium and payload reach-out is required. Ergonomically designed for hard to access work areas, the RCL incorporates an operator's handlebar that stays in position throughout the vertical work envelope.



AIM6004
mounted to articulated jib + pedestal



AIM5067

The RCL can be equipped with AIMCO's patented Pneumatic Overload Circuit which eliminates unsafe lifting conditions and protects delicate payloads.

AIMCO has several standard safety features including our "Pneumatic Overload Circuit"

SUSPENSION

Integration Options:

- Air Hoist
- Electric Hoist
- Air Balancer
- Intelligent Lifting Device (ILD)
- Hand Chain Hoist



AIM6034 mounted to articulated jib + pedestal



AIMCO's RCL
maximum capacity and reachout

250 lbs. (max)

750 ft-lbs. (max)

3 ft. reachout (max)

Best served in work cells with low ceilings, the Articulated Jib Crane + Rigid Lifting Carriage can be supplied with an *INVERTED* secondary arm. This configuration provides the ultimate low headroom system, virtually extending the work envelope from the floor to the ceiling.

**AIMCO has been in business since 1993
delivering the finest lift assist equipment available**





Options:

- Infinite float mode
- Slide handle
- Proportional controls
- Dual-load balancing control
- Base-load control

AIM5622 with a column mount + magnet grab end tool

The speed and flexibility make this system a perfect alternative to hoists. It is ideal for fast repetitive movements and the handling of fragile items. AIMCO Numo Arms are typically used in assembly processes in the general manufacturing, aviation, solar energy, and automotive industries.

The balancer is nested at the second knuckle of the arm with the load cable running through the arm and over a sheave at the end of the arm. This design eliminates the hoist "stack-up", maximizing end-of-arm clearance and minimizing end-of-arm weight.

This system offers your operation the most flexible lifting solution available. The Numo Arm also provides the most precise load handling and ergonomic benefits available on the market today.

AIMCO Manufacturing can increase your company's productivity by decreasing cycle times

Features:

- Ideal for low headroom
- Radial reach up to 15 feet
- Capacity range from 115-577lbs.
- Continuous 360° rotation
- Smooth lift/lower
- Air powered
- Quiet operation



AIM5945 with a floor mounted pedestal + custom end effector

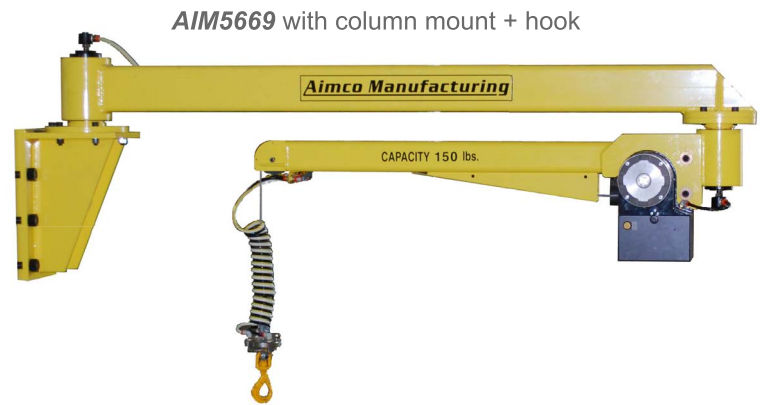

AIM5669 with column mount + hook

*Column mounted articulated jibs will have a limited primary arm rotation.

The AIMCO "Numo-Arm" is a fully integrated, pneumatic lifting system.

Air lines are internal to the arms with rotating swivels to maintain a continuous 360° rotation at the pivot bearings.

AIMCO's Numo Arm is designed with a standard mount for Konecranes' ATB Air Balancers, however custom mounts for are available for any air balancer.

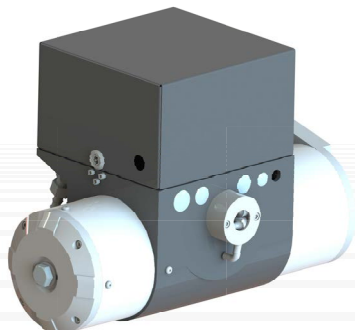

Konecranes Air Balancer

Visit our website and build your virtual lifting solution using our 3D concept generator

<http://www.aimcomanufacturing.com/buildsystem.html>





AIM6115 with a portable base mounted pedestal + pump mount + custom end effector

Options:

- Custom end effectors
- 1" and 2" diameter flow paths
- 8' to 15' radial reach
- Pedestal vacuum mount
- Wall vacuum mount
- Stainless Steel available
- NSF certified powder coat

SUSPENSION



AIM5674

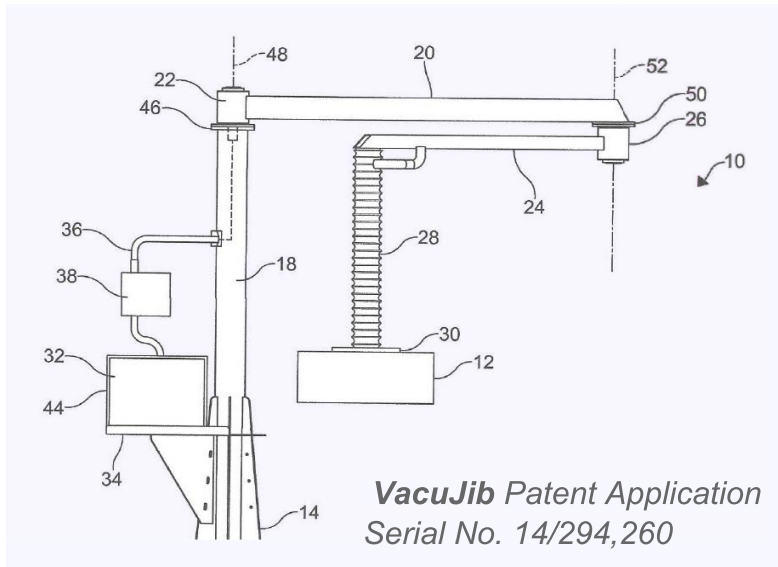

*Numbers are external references only

Standard models are available with up to 15 feet of radial reach. Standard options include a Pump Mount and a Portable Base. AIMCO's VacuJib can be mounted on a free standing pedestal, existing building column, machine, overhead ceiling structure, or a manipulator platform.

Visit our Online Video Library for demonstrations of AIMCO Manufacturing Equipment

Features:

- Universal tube lifter connections
- Radial reach up to 15 feet
- Capacity range from 70-270 lbs.
- Continuous 360° rotation
- Patent pending technology



AIM5927-B with a portable base mounted pedestal
+ pump mount + on-board power source + custom end tool

AIMCO Vacuum Series Articulating Jib with 360° continuous rotation at two pivot joints. Each pivot joint is equipped with tapered roller bearings, pre-greased and sealed, designed to a 5:1 safety factor. End of arm attachment is a clevis bracket intended for integration with a Vacuum Tube Lifter.

Vacuum chambers are internal and sealed from pedestal to end of arm. Custom pivot joints are outfitted with radial shaft seals and heavy duty o-rings to perform as a vacuum rotary union. The equivalent cross-sectional area of a 1" or 2" diameter flow path is maintained throughout the jib arm; from the pedestal's inlet, to the end of arm outlet.

The VacuJib, model VAJ150-8P-1F is a light duty jib intended for rapid pick & place applications (See Appendix E for details).

Contact an AIMCO Sales Engineer today for inquiries on radial reach & capacity upgrades





AIM5819
mounted to a portable base
+ secondary boom arm, table,
and end effector integration

Features:

- Conveyor Integration
- Mobile Bases
- Tables
- Jib Brakes
- Jib Stops
- Electrical Integration

AIM4925 with custom tool holder
+ custom tool table intergration

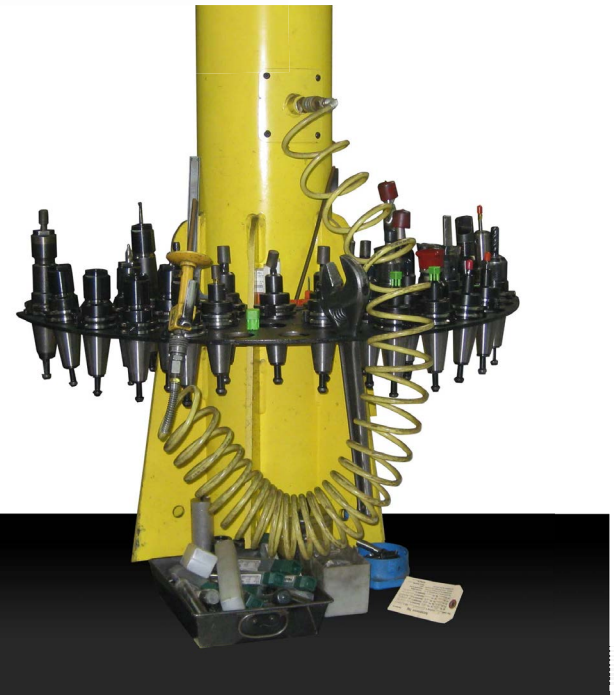

SUSPENSION

AIMCO wants to insure that your jib crane is not just a standard jib crane. Why just waste the space around the base of your jib crane when you can utilize the entire area and not lose that precious floor space.

With AIMCO's accessories, there is no need to sort through numerous tools in a drawer or to waste the entire space around the jib crane. We have many standard products in order to help you organize and utilize every inch of space at your facility.

AIMCO Manufacturing will customize its standard designs of lift assist equipment to suit your application



AIM6032
mounted to a column

Mounting Options:

- Pedestal
- Column
- Under-hung
- Trolley Platform
- Machine
- Portable Base
- Forklift
- Low Overhead



AIM5702
mounted to portable base



AIM5919
mounted to a forklift

Adding more accessories provides portability and versatility for flexible manufacturing environments.



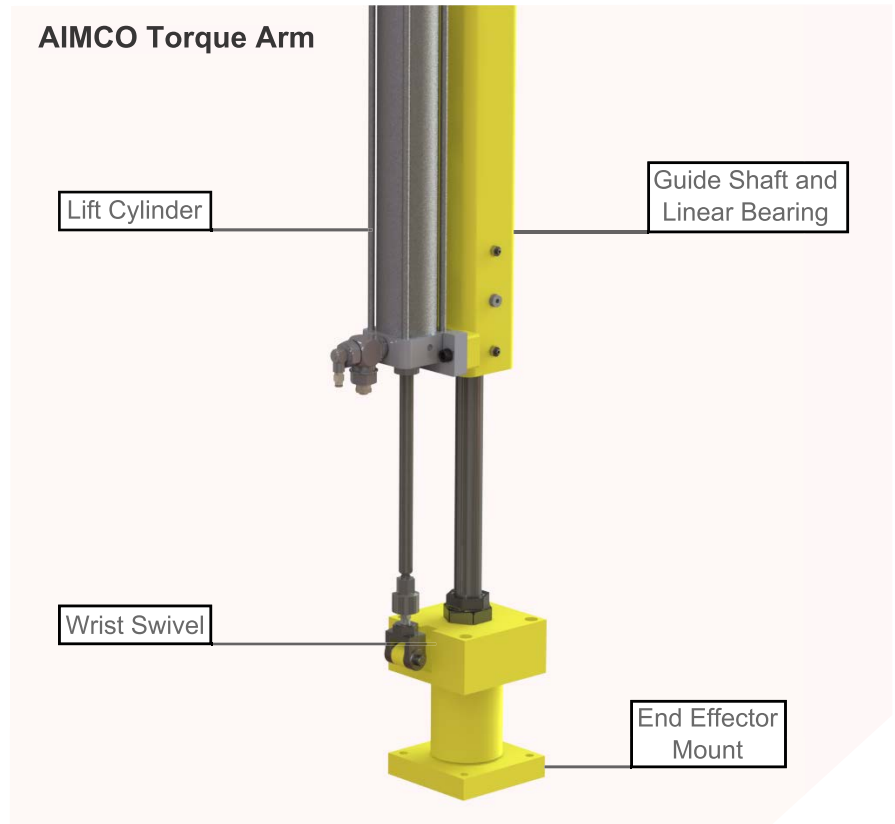

AIM5655 mounted to an articulated jib
+ custom end effector and pivoting handles

The Torque Arm employs a lifting cylinder combined with a guide shaft and linear bearing. The guide shaft prevents the lifting cylinder from experiencing any effect of side load that could cause binding or rod & seal damage. A wrist swivel with an end effector mounting plate provides rotation capability for precise tool orientation and positioning of loads. Custom end effector tooling can be designed for most applications. A torque arm can be mounted to an AIMCO Articulated Jib Crane or from a bridge crane. The AIMCO torque arm also bridges the gap between a hoist and a manipulator. It provides a rigid "load arm" between the work piece and the crane, allowing off-center loads to be securely transported and manipulated without a loss of required product orientation. Reach-in applications are accomplished in a safe, easy and ergonomic manner.

AIMCO provides a variety of both standard and custom designed tooling to safely and efficiently handle many loads

Features:

- Two button, speed metered, vertical lift control handle
- Capacities up to 1,000 lbs.
- Vertical lifts available up to 84 inches
- Operates on 90 PSI plant air
- Rotation of 359° (limited to air coil wrap around.)
- Wrist Swivel for tool/ payload positioning

TA1000
without wrist swivel



TA300
with wrist swivel



*See Appendix D for Technical Data

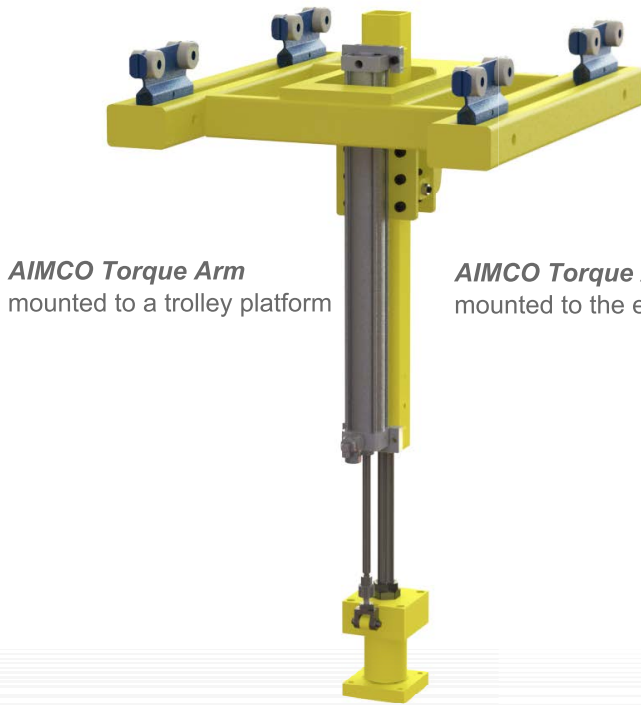

AIMCO Torque Arm
mounted to a trolley platform

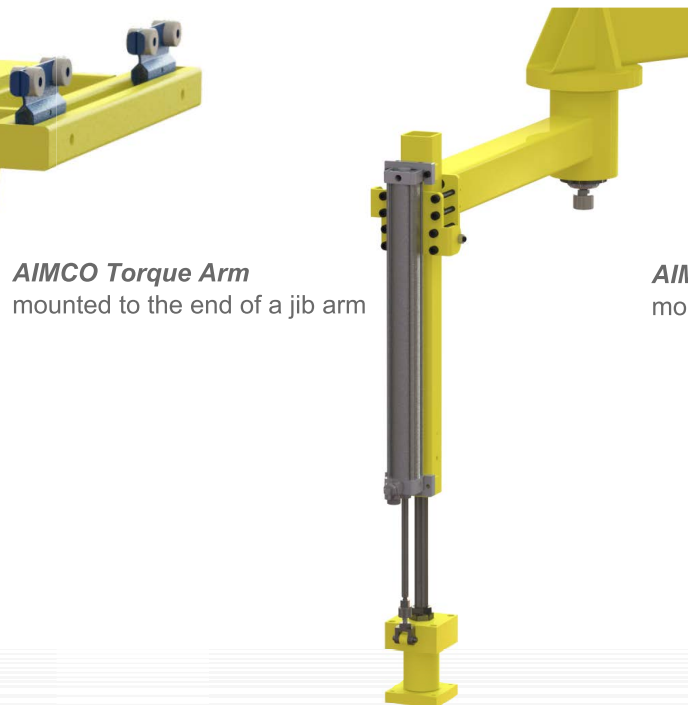

AIMCO Torque Arm
mounted to the end of a jib arm



AIMCO Torque Arm
mounted to a single trolley

LIFTING

AIMCO has extensive experience in the design of end effector tooling - from simple configurations to the complex.





Features:

- Ideal for hard to access work areas
- Vertical lift up to 10 feet
- Tool carriage up to 250 lbs payload at 36" reach-out
- Continuous 360° rotation
- Patented Pneumatic Overload Circuit

AIM5684 mounted to a trolley platform + custom end effector

AIMCO's Model RCL Low Headroom Pneumatic Lift provides maximum lift in work areas where headroom is a premium and payload reach-out is required.

Ergonomically designed for hard to access work areas.

It can be equipped with AIMCO's exclusive, patented Pneumatic Overload Circuit, which eliminates unsafe lifting conditions and protects delicate payloads. Several other options are available including additional safety features and Custom End Effectors.

An air hoist smoothly controls lift/lower movements and the swivel bearing provides 360 degree rotation. Controls are set at an ergonomic height throughout use.

***AIMCO Manufacturing can customize
to suit your application***

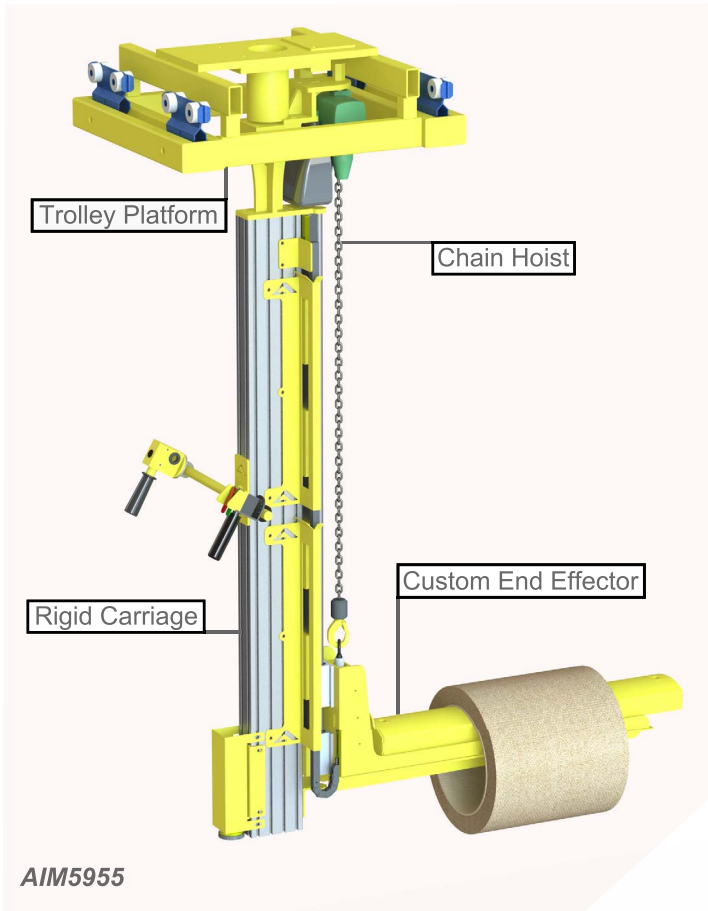

AIM5930 mounted to a trolley platform
+ miniture articulated jib arm for part reach-out

Ergonomically designed for hard to access work areas, the Model RCL was designed for off-center loads.

This system delivers a maximum lift in low headroom applications by incorporating the rigid body with a chain hoist giving travel along the entirety of the mast.

An air hoist smoothly controls lift/lower movements and the swivel bearing provides 360 degree rotation. Controls positioned at set ergonomic height throughout use. The Rigid Carriage Lift can handle up to 250 lbs payload at 36" reach-out.

AIMCO has several safety features to choose from for all of its systems





Features:

- Capacities from 100 to 500 Lbs
- Radial Reach from 6 to 11 feet
- Vertical Travel up to 60 inches
- Standard & custom end tooling available
- Continuous 360° rotation
- Available in ceiling, trolley, machine base, wall, and column mounts

AIM6129 mounted to a pedestal with a custom end effector

AIMCO's Articulated Lifting Arms are ideal for load manipulation in low headroom environments.

Lifting arms provide the ability to reach-in, around, and under obstructions while providing a safe and secure means of load handling.

The "ALA" lifting arm systems were first developed for part/rack transfer on overhead moving conveyor lines.

The arm's simplicity of design, reliability and modest cost have fostered many other industrial lift assist uses.

Use the AIMCO advantage to increase productivity, quality, profits and create a safer work environment

AIMCO Articulating Lifting Arm

AIM5648

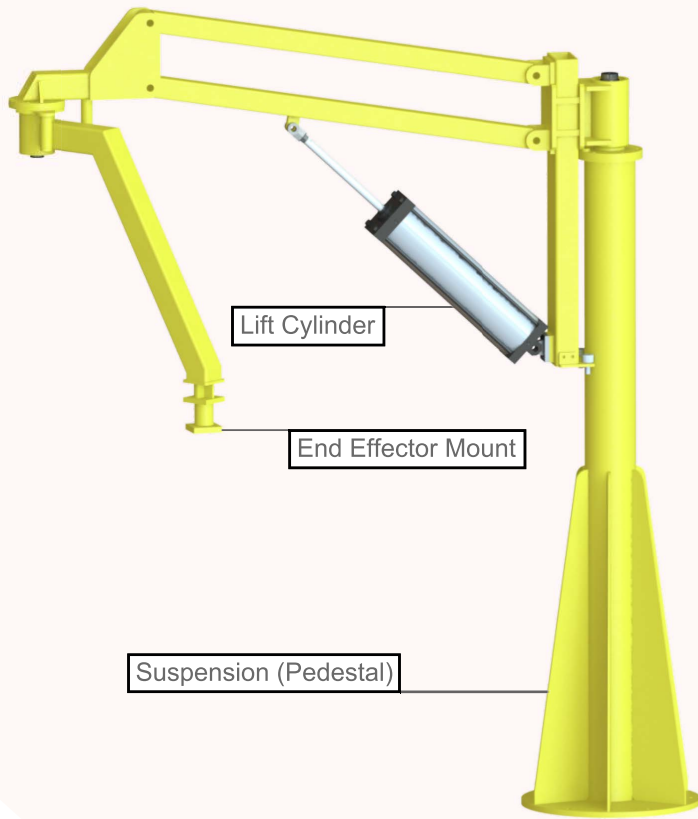

AIM5907 mounted to a pedestal
+ custom end effector with ergo handles

End of Arm Tooling for AIMCO's articulated lifting arms range from simple lifting forks to custom grippers with Mechanical Grabs or Vacuum Lifts.

Parallel linkage is standard to assure the tooling and load retain the proper orientation throughout the lift and transfer operation.

"Soft Start" cylinders with speed adjustment provide for a smooth, regulated lift and lower motion.

AIMCO Manufacturing can increase your company's productivity by decreasing cycle times



AIM6086 mounted to a bridge crane suspension with a vacuum tool



AIMCO Pos-A-Lift mounted to a bridge crane suspension with 360° swivel air connection

(Optional Custom Shroud Protection Available)

Features:

- Ideal for repetitive heavy parts loading
- Capacity up to 1,000 lbs
- Stroke up to 84 inches
- Allows loads to be handled with speed and precision
- Straight rod reduces drag and overtravel problems
- Available with 360° swivel air connection
- Works great with ACU end tooling

The Pos-A-Lift is a pneumatic lifting mechanism (hoist) that acts as a straight rod between the load and the support.

The load can be set to "float" by making the load virtually weightless, it is far easier to position and set loads with speed and precision while in float.

The straight rod reduces drag and overtravel problems, inherent with conventional chain and wire rope hoists. The Pos-A-Lift is ideal for performing quick picking and placing of parts.

*Not suited for manipulation of off-center loads. See AIMCO Torque Arm section for off-center loading.

The Pos-A-Lift can use either a Pistol Grip Metering Valve, ACU Throttle Handle or a Balancing Circuit as a control

Features:

- Ideal for zero gravity lifting and torque tool operations
- Capacities from 50 to 300 lbs
- Capable of handling up to 430 Nm or 315 ft-lbs of torque
- Operates on 90 PSI plant air
- 360° swivel air connection
- Custom tool mounts available
- Adjustable bearings

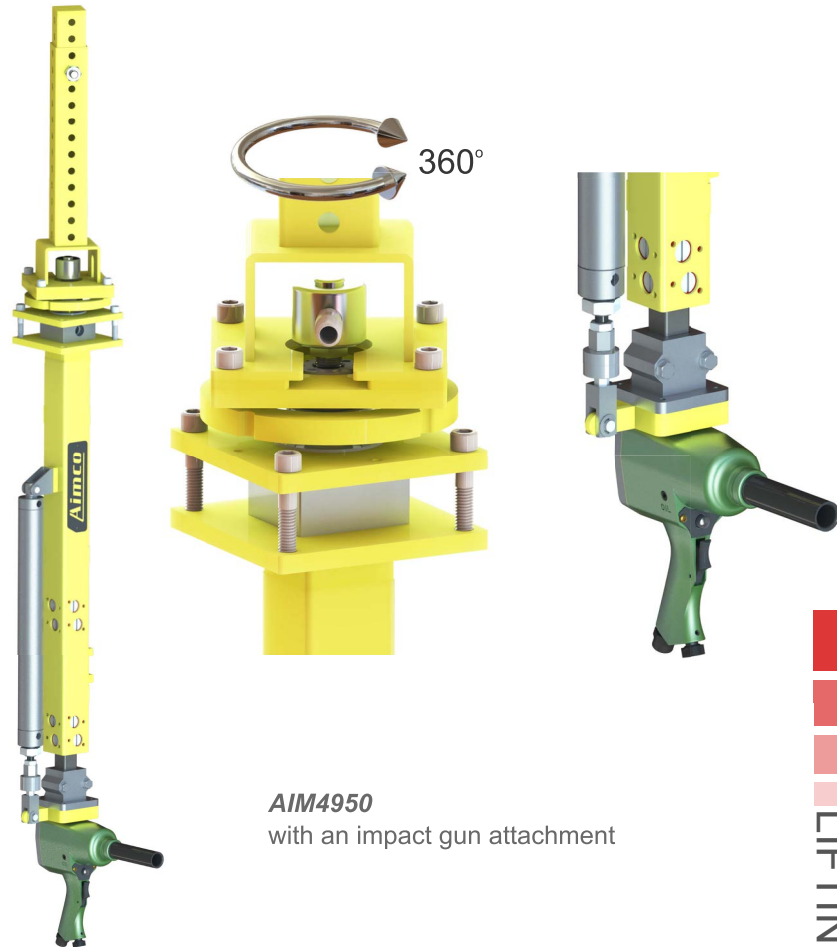

AIM4950
with an impact gun attachment

Torque Reaction Arm

The AIMCO Manufacturing Torque Reaction Arms offer zero-gravity balancing and absorb the torque reaction for your applications.

With capacities of 300 lbs and up to 315 ft-lbs (430 Nm) of torque, AIMCO's Torque Reaction Arms will be able to handle your zero gravity needs.

Standard models include a fixed mount with a basic mounting plate, however, customization of the product can include a 360 degree swivel and customization of the base plate to allow correct alignment with your tool.

There are multiple mounting options for different environments. Please call us and we can walk through which type of mounting style would best serve your needs.

Call one of our dedicated system engineers and we can help you choose the correct Torque Reaction Arm for your application.





AIM5861 ACU force sensing grab with custom end effector and handle bars (Shown at Promat 2013)



Gorbel G-Force Servo Hoist (supplied by other)

Intelligent Lifting Device:

- Infinite speed control
- Capacity up to 1,320 lbs.
- Pinpoint precision
- Capacity overload
- Power loss protection
- Operator present function
- Float Mode
- Button-less controls when using ACU end tooling

**AIMCO does not sell or distribute Gorbel products*

Gorbel's Intelligent Lifting Devices give you the best of both worlds: the responsiveness and flexibility of a human operator plus the power of a machine.

They incorporate a range of speeds, making them perfect for quick, repetitive motions and slow, precise placements.

When used with AIMCO jibs and/or end tooling, the two come together to create one of the safest and high tech lifting devices available. This integration has been displayed at trade shows and has been gaining interest in the industry for several years.

AIMCO is a preferred custom end tool supplier for Gorbel and offers custom integration.

Features:

- Ideal for applications not requiring rigid lifting
- Capacities from 50 to 1,600 lbs.
- Various mounting options available including jibs and trolleys
- Air or Electric Operation
- Safety options available
- Standard tooling available
- Custom end tooling available

Air Balancer
(For Numo and Konecranes AirGo Arms)

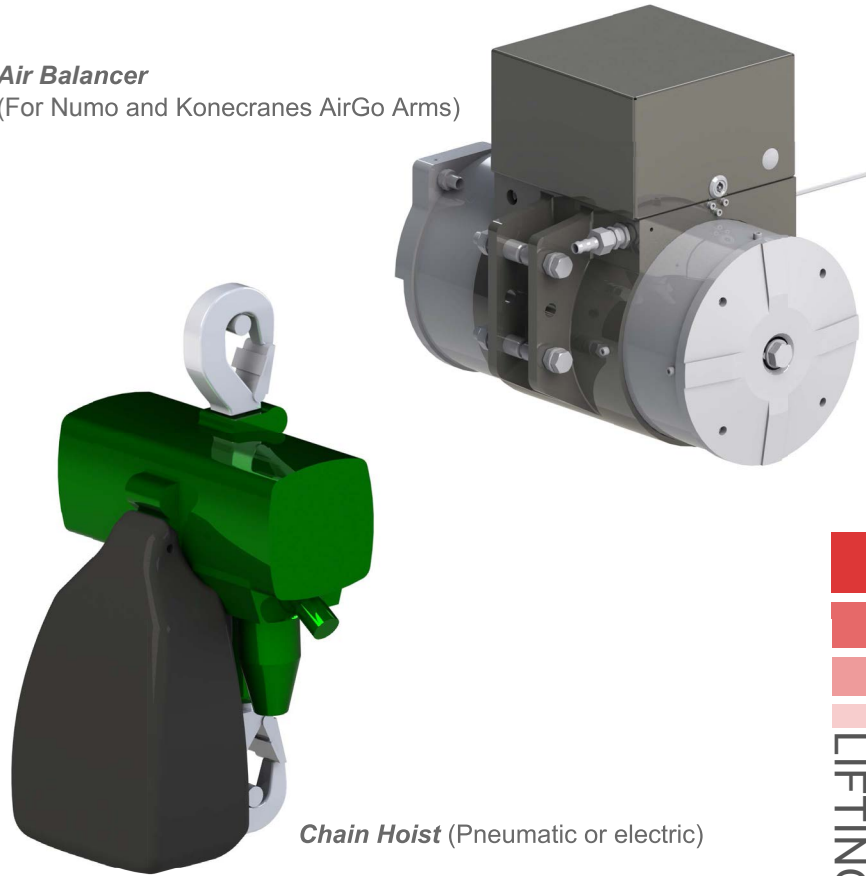

Chain Hoist (Pneumatic or electric)

The chain hoist widens the range of applications as a handy, flexible and universally deployable hoist making it an ideal tool for a wide range of manufacturing and assembly applications. With this lifting mechanism loads can be lifted, lowered, manually traversed and positioned with only one hand.

The air balancer is unique in lifting technology. Using a floating load unit, it harnesses air pressure as the power source. Any load up to 770 lbs. feels almost weightless as you move it to where you need it. Air balancing equipment is excellent for assembly processes, repair, and industrial production tasks in many industries, including manufacturing, solar energy, automotive, railroad, aviation, health care, and food.

AIMCO integrates its tooling, suspension and lifting devices with several other industry leading companies.





Options:

- Dual Density Pads
- Non-Marring Jaws
- Incremental Rotation
- Tilt/Rotate
- Adjustable Jaws

AIM5531 MG125-2J
mounted to an Aimco Rigid Lift System

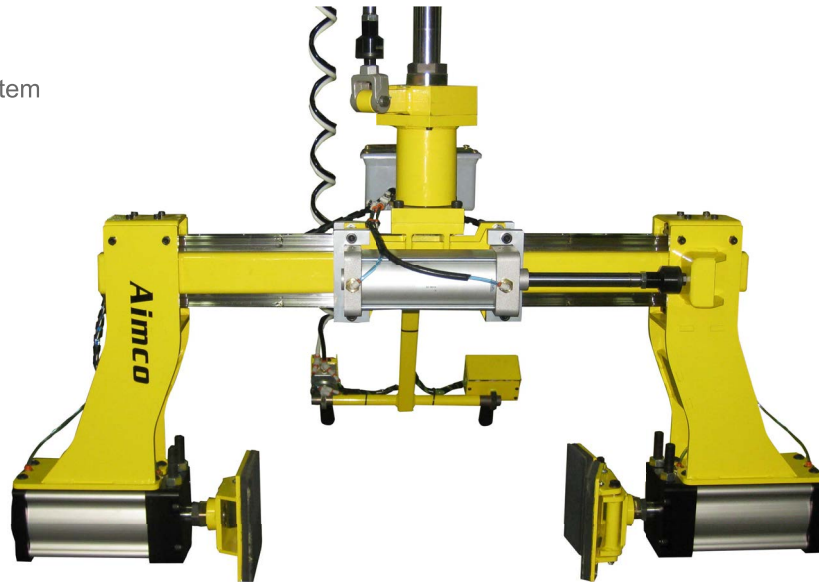

AIM5989 MG400-3J/PT180
OD Grab and Flip

Pneumatically powered mechanical clamping systems can be difficult to spec' in properly. AIMCO's extensive experience in designing and manufacturing puts your mind at ease when tackling a seemingly complex project.

Our products are manufactured and assembled in our 9001:2008 ISO certified 100,000 square foot facility in Toledo, Ohio.

Our in-house machining and fabricating capabilities support customers' need and problem solving efforts.

TOOLING

Features:

- 2-Jaw or 3-Jaw Configurations
- OD & ID Clamps
- Capacity up to 1,000 Lbs.
- Capacity up to 500 Lbs. (with part manipulation)

AIM5825 MG400-2J/PT180

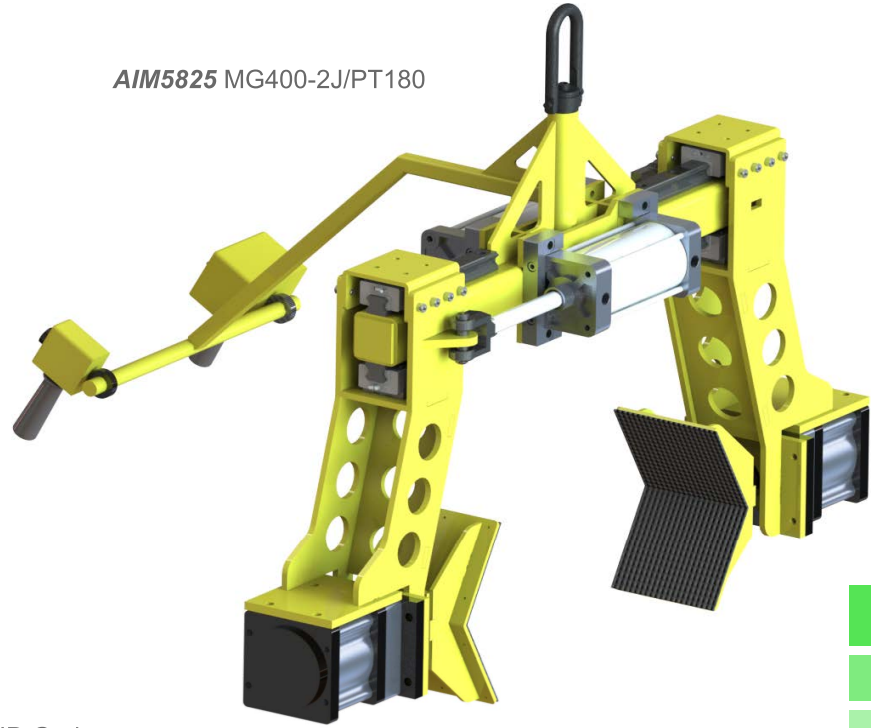

AIM6055 MG130-3J ID Grab



AIM5915 MG50-2J/MT180
OD Grab with Manual Tilt

The Mechanical Grab series comes in all shapes and sizes with lifting capacities ranging from 20 - 1,000 pounds. They incorporate a wide array of gripping mechanisms to secure various parts.







This style of tooling incorporates pneumatic power to clamp and or encapsulate parts for safe handling. For radial surfaces, three-point contact is recommended for optimal security.

TOOLING

Our engineers and production staff work hard every day to develop and produce the finest industrial lift assist systems available.



Component Options:

-  Anver
-  Edco
-  Piab
-  Schmalz
-  SMC
-  Vacuforce

AIM6086-U
Model VG600-4C

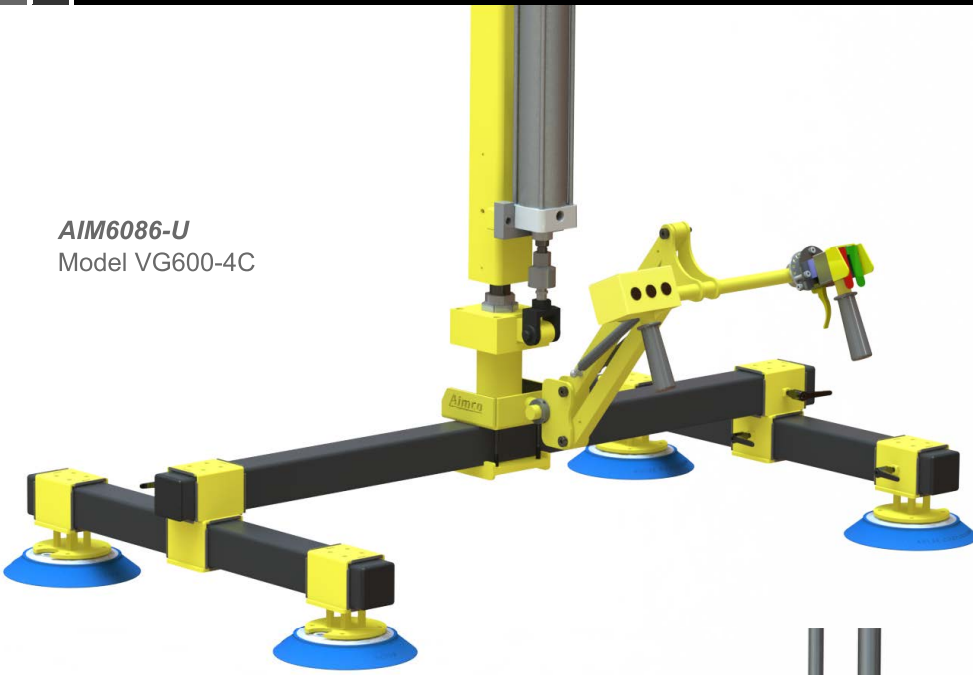

AIM6130 end effector with 90° tilt
Model VG200-6C/PT90

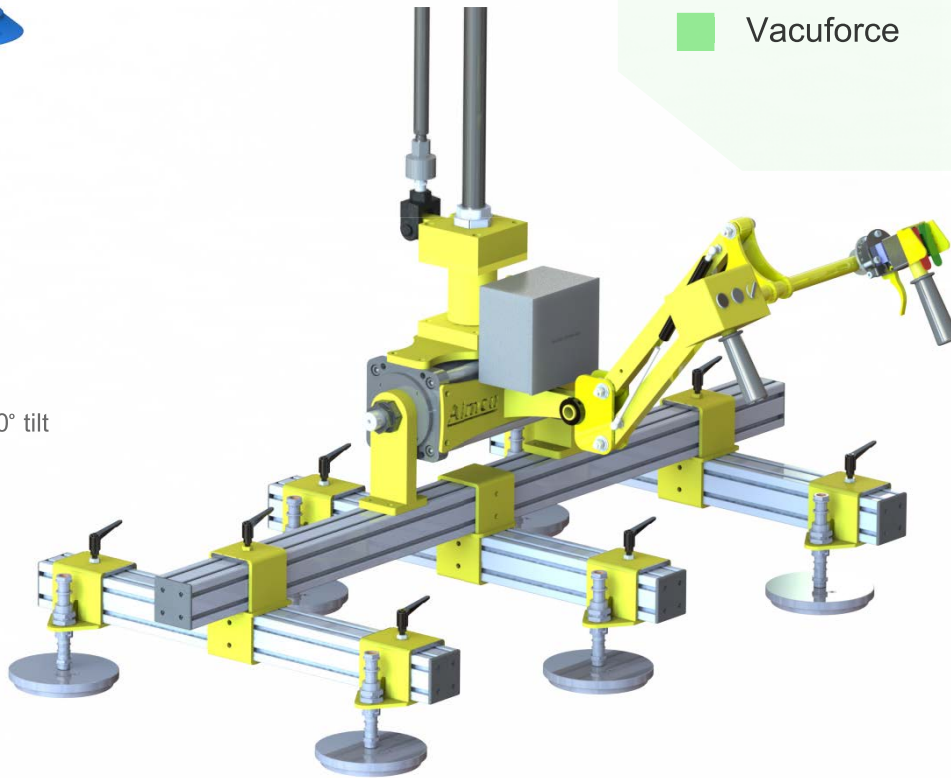

TOOLING

AIMCO Vacuum Grab End Tools are available with a variety of vacuum components, carefully specified to fit the application. Custom vacuum cup configurations can be designed with adaptable spreader beams. Loads can be tilted, rotated, or inverted.

End Tooling Capacity up to 1,000 Lbs.
(Capacity up to 500 Lbs. with part manipulation)

Features:

- Loads up to 1,000 lbs.
- Vacuum Blow-Off
- "Loss of Air" (Safety)
- Quiet Operation
- Custom Cup Configuration
- Optional Part Manipulation



AIM6023 Model VG90-2C/PT180
mounted to a Torque Arm and Articulated Jib Crane

AIMCO vacuum lifters can be found in many factories across North America handling glass, sheet metal, cabinets, body panels, counter-tops, and furniture.

AIMCO's Vacuum Grab end tools utilize Venturi vacuum systems powered by plant compressed air. These systems are ideal for applications where the surface of the product is non-porous. This method of vacuum generation is a safe and reliable means of product handling that places very little demand on plant air consumption.

***AIMCO has been in business since 1993
delivering the finest lift assist equipment available***



Suitable for:

- Ferrous Parts Only
- Perforated Surfaces
- Offloading Laser Machines
- 26 ga to 3/4" Low Carbon Sheet Steel
- Destacking Applications

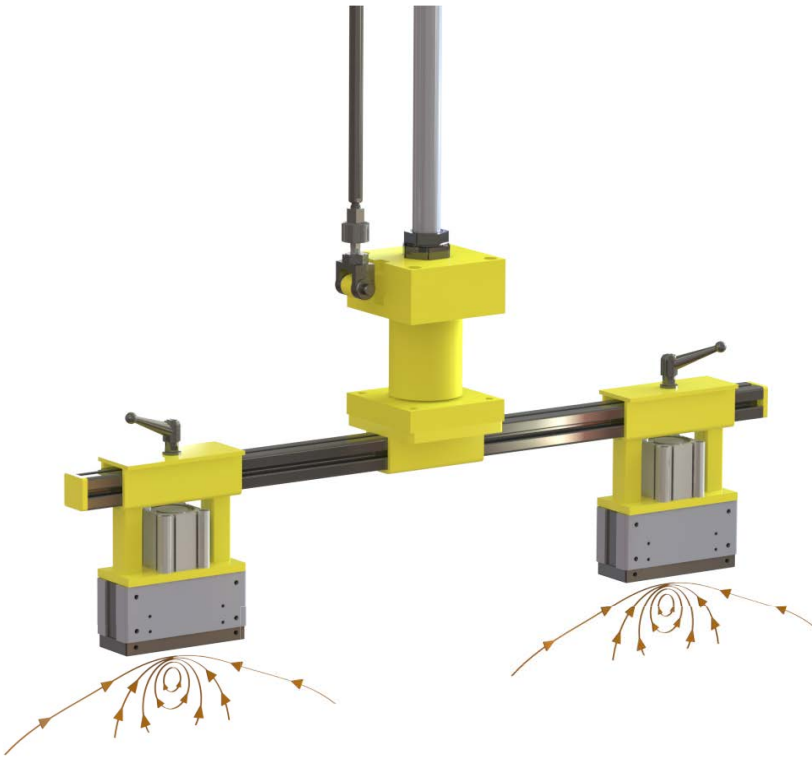

AIM6071 on a Spreader Beam
Model MAG140-2M

AIM5656 suspended from an Air Balancer
Model MAG80-1M



TOOLING

AIMCO Magnet Grab end effectors incorporate air-release magnet assemblies. Each assembly includes a rare earth, high energy, neodymium permanent magnet for grabbing parts. Release of parts is achieved by way of an in-line air cylinder that effectively disengages the ferromagnetic part from the magnet. A "covered" magnet incorporates a stainless steel shroud and pusher plate to keep unwanted particles from collecting on the face of the magnet.

AIMCO provides a variety of both standard and custom designed tooling to safely and effeciently handle many loads

Features:

- Custom Mounting Configurations
- Inherent Loss of Air Safety
- Integration with IMI Magnets
- Optional Part Manipulation

AIM6117
with an ACU Control
Model MAG120-1M



AIM5580 mounted
on a Torque Arm
Model MA150-4M/PT90



Great for fast part engagement and quick release. This series of end tooling makes picking of jumbled parts easy and efficient.

Magnetic part holding is a good solution for carbon steel parts with diversified features such as scattered holes or complex surfacing.

AIMCO Manufacturing is a proud employee owned company



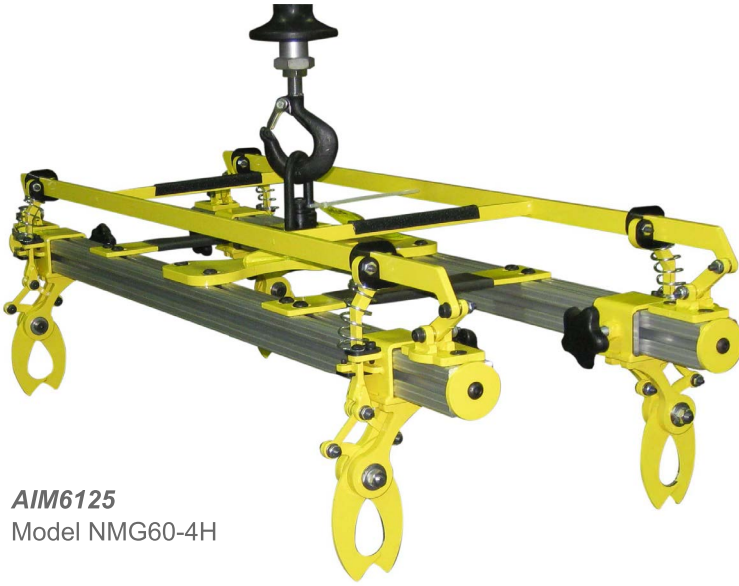

AIM6125
Model NMG60-4H

Features:

- Load Tested & Certified
- Custom Configured Forks & Hooks
- Build-to-Order Tools Available
- Capacity up to 1,000 Lbs.
- Capacity up to 500 Lbs. (with part manipulation)



AIM5985
Model NMG200-2J



AIM4935
Model NMG350-2J



AIM5810
Model NMG80-2J

TOOLING

AIMCO Non-Powered Mechanical Grab (NMG) End Effectors are a great choice for "pick & place" applications. If the part being handled has a common feature such as holes, pockets, or lifting eyes then an NMG with probes, forks, or hooks is the simplest and most economical solution.

AIMCO has extensive experience in the design of end effector tooling - from simple configurations to the complex

Tooling Options:

- Non-marring Pads
- Adjustable Mounts
- Pantograph Gripping
- Spring Returns
- Part Locators
- Manipulation
- Safety Clasps



AIM6120
Model NMG250-1H
mounted to a Torque Arm



AIM5570
Model NMG600-2H
suspended from a Chain Hoist



AIM5632
Model NMG125-2F/PR180
mounted to a Torque Arm

Featuring state-of-the-art equipment, our Fabrication division incorporates the latest technology and offers a wide variety of services including CNC Laser Cutting, MIG & TIG Welding, Forming & Punching, Wire Forming, and Powder Coating. These services are embodied in every end effector that leaves our facility.

Adding more accessories provides portability and versatility for flexible manufacturing environments

AIM6069
Model VG80-2C/PR90

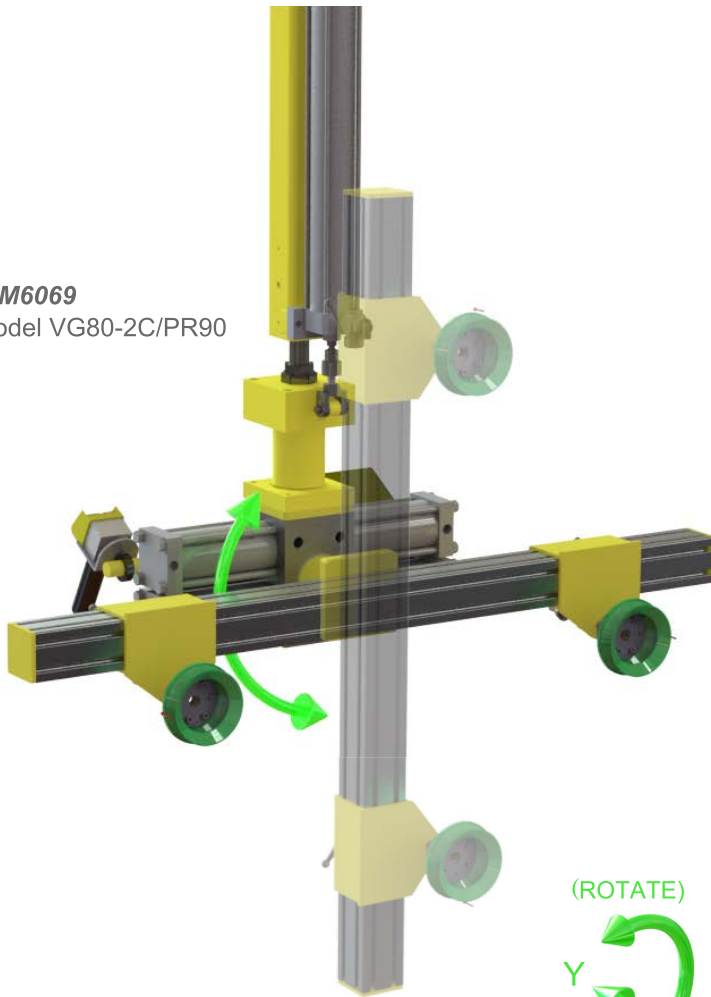

Features:

- Powered Rotation
- Powered Tilt
- Powered Yaw
- Powered Slides
- Integrated Logic
- Non-Powered Manipulation Available

TOOLING

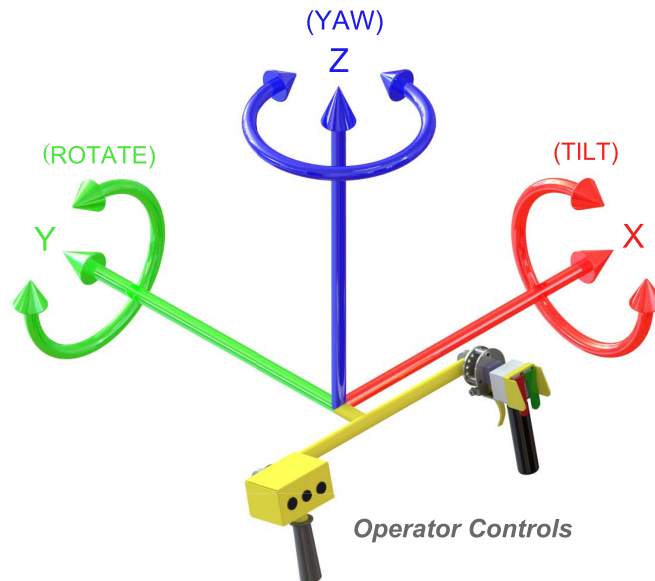

Manipulating features can be integrated into if & then logic, timing circuits, incremental jog circuits, selector switches, and momentary buttons. Custom air logic packages can be configured to fit various part manipulation applications.

Visit our website and use the Concept Generator to create a model for your application

Options:

- Incremental Jog Control
- Combine Manipulations
- Integrated Safeties
- Rack & Pinion
- Vane Actuator
- Cylinder & Linkage

AIM6030
MG220-2J/PT90
Showing 90 degree tilt



AIM6022
MG120-2J/PT180
Showing 180 degree tilt

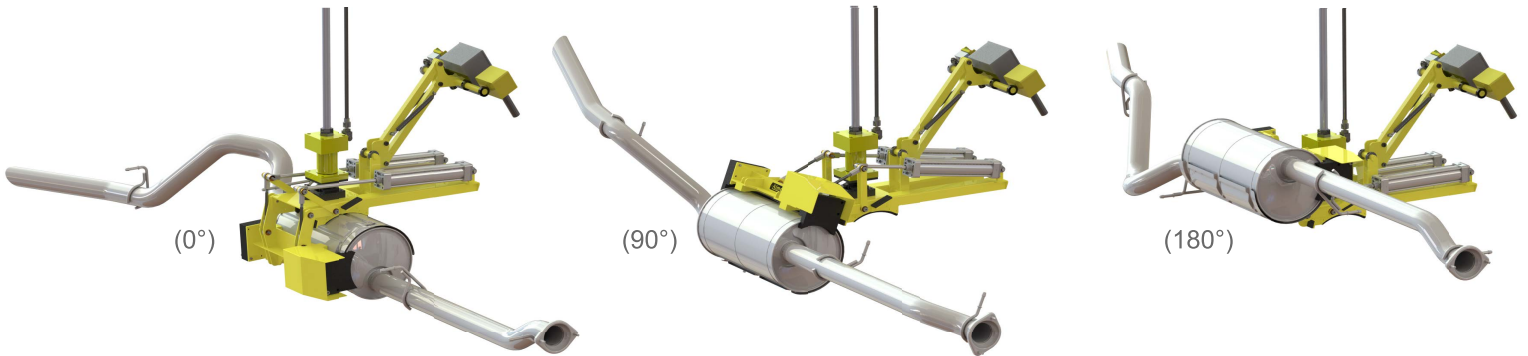

AIMCO's tooling manipulation offers extraordinary time efficiencies and cost savings. If a part needs flipped, an AIMCO end effector can accomplish a change of orientation during transit.

Our Articulated Jib Cranes integrate with several other lifting devices





Features:

- Control handles with up to 4 buttons
- Recessed momentary buttons
- Rocker-style switches
- Various 2-position and 3-position toggle switches
- Air Logic Enclosure

Up/Down and Tilt Air Logic Box inside view of logic enclosure

TWO BUTTON CLAMP/UNCLAMP OR VACUUM ON/OFF CONTROL

Provides individual buttons for the clamp and unclamp of a gripper mechanism or the vacuum on and off of a vacuum tool. Both buttons are housed in a single control handle assembly for ease of use.

ONE-BUTTON "ALWAYS CLAMPED CIRCUIT"

Adds a simple safety that requires the operator to push and hold a recessed button for part release from the end tooling. This prevents the operator from inadvertently tripping an unclamp or vacuum off button.

PART MANIPULATION

Typical controls include, but are not limited to, recessed momentary buttons, rocker-style switches, and various 2-position & 3-position toggle switches.

Custom Air-Logic Packages can be configured to fit various part manipulation applications

Features:

- Standard up/down pendant
- Custom holsters for existing hoist pendants
- Infinite float mode available with air balancers and electric hoists
- Enhanced Operator Safety
- Reduced Operator Fatigue



Vertical Slide Handles
with up/down pendant and mag
pendant with tilt function

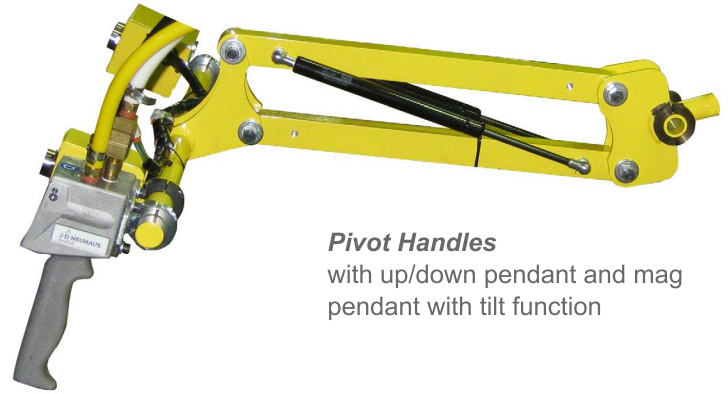

Pivot Handles
with up/down pendant and mag
pendant with tilt function

Particularly for applications requiring vertical strokes beyond 48 inches, an *Ergonomic Handlebar* is crucial to maintaining a safe and comfortable experience for the operator.

PIVOTING HANDLEBARS

Presents the most economical solution for staying within the “ergonomic zone”. This design incorporates parallel linkages and gas shocks to counter-balance the weight of the operator’s control handles, and is available with 25 inches of travel.

VERTICAL SLIDE HANDLES

Utilize a pneumatically balanced circuit that keeps the operator’s control handles in a floating-state. Vertical strokes range from 20” – 40”.

**AIMCO offers several optional devices to
make our systems safer and more ergonomic.**



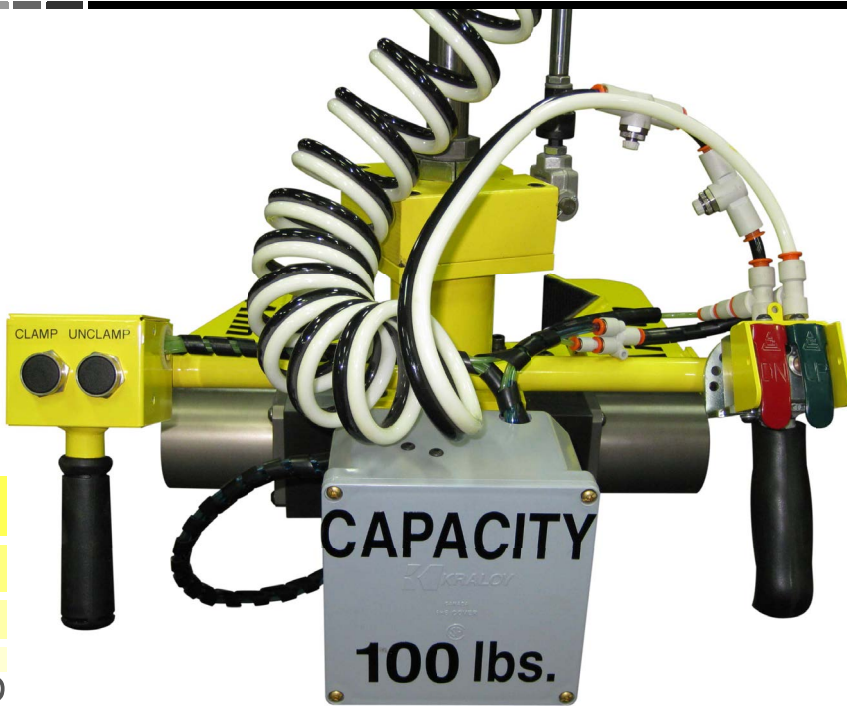

Mechanical Grab End Effector
with up/down pendant and clamp/unclamp pendant

Features:

- Standard up/down pendant
- Custom holsters for existing hoist pendants
- Dual-load and triple-load weight control
- Infinite float mode available with air balancers and ILD
- Enhanced Operator Safety
- Reduced Operator Fatigue

CONTROLS & SAFETIES

PISTOL GRIP METERING VALVE, (PGMV)

Is standard and most popular. Air is metered into the air cylinder through two thumb levers. Vertical motion speed is adjusted by depressing a thumb lever, with maximum speed when lever is fully depressed. No adjustment is required for multiple load weights to be picked. The operator has infinite variable speed control that reduces the operator's efforts during vertical movement of the load.

BALANCE CONTROL CIRCUIT

Allows for near zero gravity lift and lower without up/down levers. The gripper control acts as a selector switch to preset one of two load regulators indicating a load is present or the unit is unloaded. The operator simply lifts or lowers the tool or the load in a balanced condition.

DUAL WEIGHT LOAD CONTROL (DWLC)

Provides a balance control circuit for two different load weights. This control acts identically to the balance control circuit with the addition of a toggle switch to indicate whether load weight #1 or load weight #2 is being handled

Contact an AIMCO Sales Engineer today for inquiries on radial reach & capacity upgrades

Features:

- Loss of Air
- Set Down Safety
- Loss of Vacuum
- Two Hand Control
- Static Release



Operator's Handlebar
with clamp/unclamp pendant, load and no load safety with common button

CONTROLS & SAFETIES

LOSS OF AIR SAFETY

Is standard on all AIMCO lift assist equipment. Systems are equipped with blocking valves to prevent the arm and/or load from falling in the event of a loss or disruption in air supply.

"SET-DOWN" LOAD AT REST SAFETY

Is a logic package that prevents the load from being released from the end tooling until it has been set upon a supportive surface. This safety cannot be provided with the Balance Control Circuit.

PNEUMATIC OVERLOAD CIRCUIT (AIM7000)

Mounted between the tooling and the hoist hook, the AIM7000 uses a pilot air signal to disable the up button of the hoist. If the tooling or payload snags on an obstruction, the operator simply lowers the hoist away from the obstruction before the hoist can cause any damage.

***For more demonstration on our system safeties,
visit our AIMCO Video Library online.***



CONTROLS & SAFETIES



Order Code: *ACU-VGN100-2X-KL-M12X36*

Features:

- Ergonomically optimal, button-less control system
- Great for rapid pick and place applications
- Capacities available up to 200 LBS
- Can be integrated with various lifting devices
- Several UP/DOWN controllers to choose from
- Structurally designed to a 5:1 safety factor

About our ACU

AIMCO offers a new variety of custom end tooling, to allow for automatic clamping and unclamping of parts for quick, easy and accurate part handling. With the "ACU", production can be faster and safer within your work environment. Each system comes standard with safety features, including an inherent safety set down and varying loss-of-air safeties. The three types of part clamping that can be used with this system include Vacuum, Magnet, and Mechanical. Call one of our dedicated system engineers today for assistance in configuring your application's ACU.



Order Code: *ACU-MAG140-2X-GF-M12X36*

AIMCO has several standard safety features including our "Pneumatic Overload Circuit"



Custom Mechanical Grab
Order Code: **ACU-ACE200-GF-M48X48**

Our ACU Continued

The "ACU" series promotes optimal ergonomics by using a button-less clamping controller intended to be coupled with a button-less lifting device controller. The ACU control package has been carefully designed so that it may be integrated with an Intelligent Lifting Device, Air Balancer, Air Hoist, or an AIMCO Pos-A-Lift.

AIMCO now offers a quick ship program for the ACU! If you can build an order code to fit the demands of your application, your configured ACU qualifies for the program. Simple as that. Call a customer service representative today for more information.



Order Code: **ACU-VGN30-1Z-GL-M16X16**

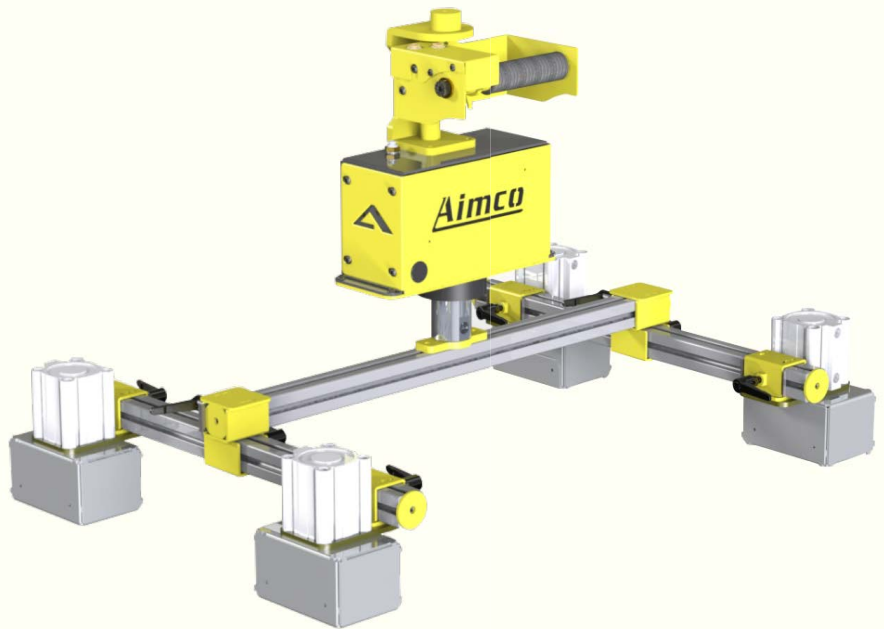

Order Code: **ACU-MAG160-4XY-AT-M48X48**

AIMCO has several safety features to choose from for all of its systems





Articulated Jib Size and Capacity

MODEL NO.	CAPACITY		REACH		A	B	H1	H2	ØD	P	S	T
	(LBS)	(KG)	(FT)	(M)	(IN)	(IN)	(IN)	(IN)	(IN)	(FT)	(IN)	(IN)

AIMCO "Bantam" Series

BAJ150-8	150	68	8	2.4	56	40	13.5	7	20	8 to 13	2	0
BAJ135-9	135	61	9	2.7	63	45	13.5	7	20	8 to 13	2	0
BAJ125-10	125	57	10	3.1	70	50	13.5	7	20	8 to 13	2	0
BAJ115-11	115	52	11	3.4	77	55	13.5	7	20	8 to 13	2	0
BAJ100-12	100	45	12	3.7	84	60	13.5	7	20	8 to 13	2	0
BAJ90-13	90	41	13	4.0	91	65	13.5	7	20	8 to 13	2	0
BAJ85-14	85	39	14	4.3	98	70	13.5	7	20	8 to 13	2	0
BAJ80-15	80	36	15	4.6	105	75	13.5	7	20	8 to 13	2	0

AIMCO "Standard" Series

SAJ675-8	675	306	8	2.4	56	40	17	10	30	8 to 12	3.5	0
SAJ600-9	600	272	9	2.7	63	45	17	10	30	8 to 12	3.5	0
SAJ550-10	550	250	10	3.1	70	50	17	10	30	8 to 12	3.5	0
SAJ495-11	495	225	11	3.4	77	55	17	10	30	8 to 12	3.5	0
SAJ450-12	450	204	12	3.7	84	60	17	10	30	8 to 12	3.5	0
SAJ415-13	415	188	13	4.0	91	65	17	10	30	8 to 12	3.5	0
SAJ385-14	385	175	14	4.3	98	70	17	10	30	8 to 12	3.5	0
SAJ360-15	360	163	15	4.6	105	75	17	10	30	8 to 12	3.5	0

AIMCO "Heavy" Series

HAJ1625-8	1,625	738	8	2.4	56	40	19	10	30	8 to 12	4	1.5
HAJ1445-9	1,445	656	9	2.7	63	45	19	10	30	8 to 12	4	1.5
HAJ1300-10	1,300	590	10	3.1	70	50	19	10	30	8 to 12	4	1.5
HAJ1190-11	1,190	540	11	3.4	77	55	19	10	30	8 to 12	4	1.5
HAJ1085-12	1,085	493	12	3.7	84	60	19	10	30	8 to 12	4	1.5
HAJ1000-13	1,000	454	13	4.0	91	65	19	10	30	8 to 12	4	1.5
HAJ930-14	930	422	14	4.3	98	70	19	10	30	8 to 12	4	1.5
HAJ865-15	865	393	15	4.6	105	75	19	10	30	8 to 12	4	1.5

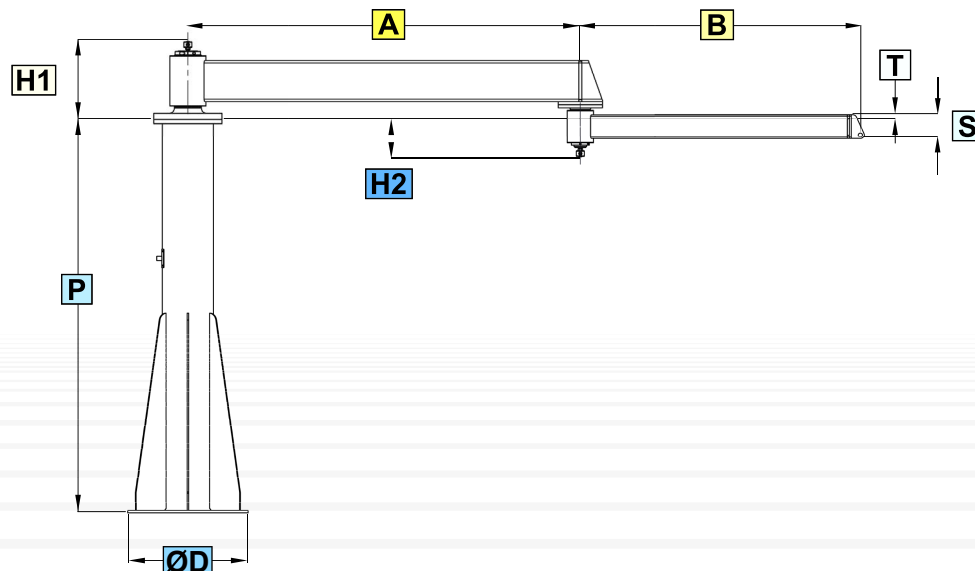

VacuJib Size and Capacity



MODEL NO.	CAPACITY		REACH		A	B	H1	H2	ØD	P	S	T
	(LBS)	(KG)	(FT)	(M)	(IN)	(IN)	(IN)	(IN)	(IN)	(FT)	(IN)	(IN)
AIMCO 1" Flow Series												
VAJ150-8	150	68	8	2.4	56	40	8.75	5.8	20	8 to 13	5.7	0.25
VAJ135-9	135	61	9	2.7	63	45	8.75	5.8	20	8 to 13	5.7	0.25
VAJ125-10	125	57	10	3.1	70	50	8.75	5.8	20	8 to 13	5.7	0.25
VAJ115-11	115	52	11	3.4	77	55	8.75	5.8	20	8 to 13	5.7	0.25
VAJ100-12	100	45	12	3.7	84	60	8.75	5.8	20	8 to 13	5.7	0.25
VAJ90-13	90	41	13	4.0	91	65	8.75	5.8	20	8 to 13	5.7	0.25
VAJ80-14	80	36	14	4.3	98	70	8.75	5.8	20	8 to 13	5.7	0.25
VAJ70-15	70	32	15	4.6	105	75	8.75	5.8	20	8 to 13	5.7	0.25

AIMCO 2" Flow Series												
VAJ270-8	270	122	8	2.4	56	40	9.50	7.5	20	8 to 12	6.4	0.75
VAJ260-9	260	118	9	2.7	63	45	9.50	7.5	20	8 to 12	6.4	0.75
VAJ250-10	250	113	10	3.1	70	50	9.50	7.5	20	8 to 12	6.4	0.75
VAJ240-11	240	109	11	3.4	77	55	9.50	7.5	20	8 to 12	6.4	0.75
VAJ225-12	225	102	12	3.7	84	60	9.50	7.5	20	8 to 12	6.4	0.75
VAJ200-13	200	91	13	4.0	91	65	9.50	7.5	20	8 to 12	6.4	0.75
VAJ175-14	175	79	14	4.3	98	70	9.50	7.5	20	8 to 12	6.4	0.75
VAJ150-15	150	68	15	4.6	105	75	9.50	7.5	20	8 to 12	6.4	0.75

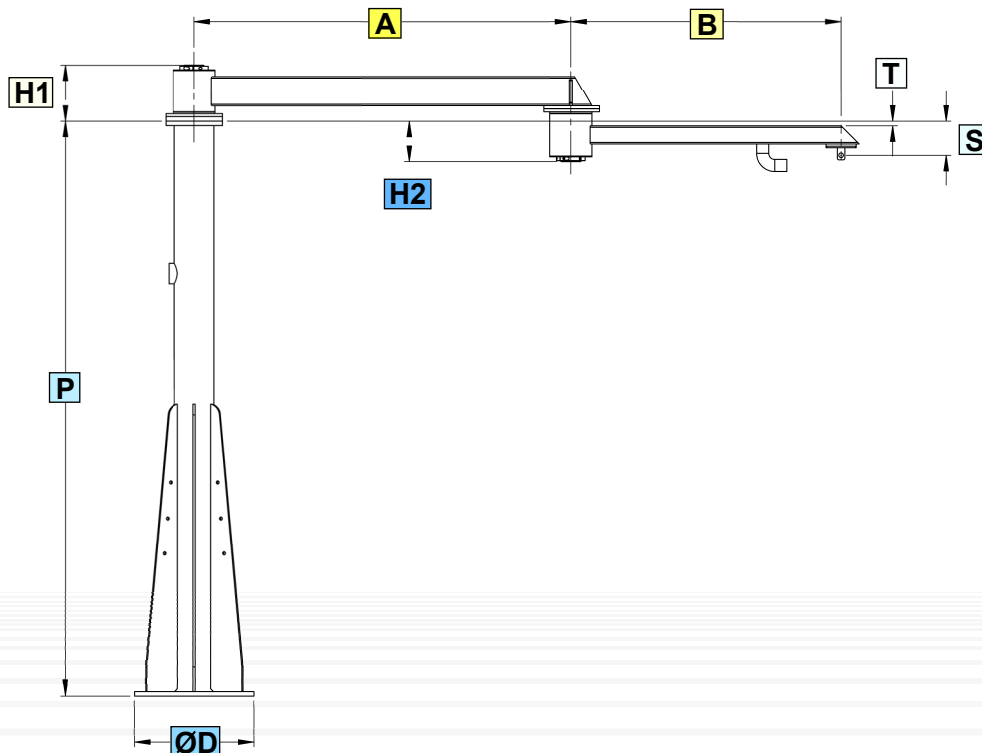

4x4 Portable Base Capacity Chart (Empty Base Weight 1800)

REACH	TOTAL BASE WEIGHT (LBS)						
	3800	4300	4800	5300	5800	6300	6800
8 ft.	248	281	313	346	379	375	444
9 ft.	213	241	269	297	325	322	381
10 ft.	186	211	235	260	284	282	333
11 ft.	166	187	209	231	253	251	296
12 ft.	149	169	188	208	228	226	267
13 ft.	136	153	171	189	207	205	243
14 ft.	124	141	157	173	190	188	223
15 ft.	115	130	145	160	175	174	205

3x3 Portable Base Capacity Chart (Empty Base Weight 1200)

REACH	TOTAL BASE WEIGHT (LBS)		
	3200	3700	4200
8 ft.	148	171	194
9 ft.	128	148	168
10 ft.	113	131	148
11 ft.	101	117	133
12 ft.	91	106	120
13 ft.	83	97	110
14 ft.	77	89	101
15 ft.	71	82	93

AIMCO Portable Base with:

Structural steel ballast base
 Measuring 3ft. x 3ft. x 2ft. OR
 4ft. x 4ft. x 2 ft. deep.
 Fork pockets internal to base
 Four leveling pads
 It is required that the ballast base be
 filled with steel shot to a pre-determined
 weight to provide the required safety factor
 (total weight including base).
 Steel shot supplied by other
 Empty ballast weight 4x4 = 1,800 lbs.
 Empty ballast weight 3x3 = 1,200 lbs.
 Mesh S70 steel shot recommended.

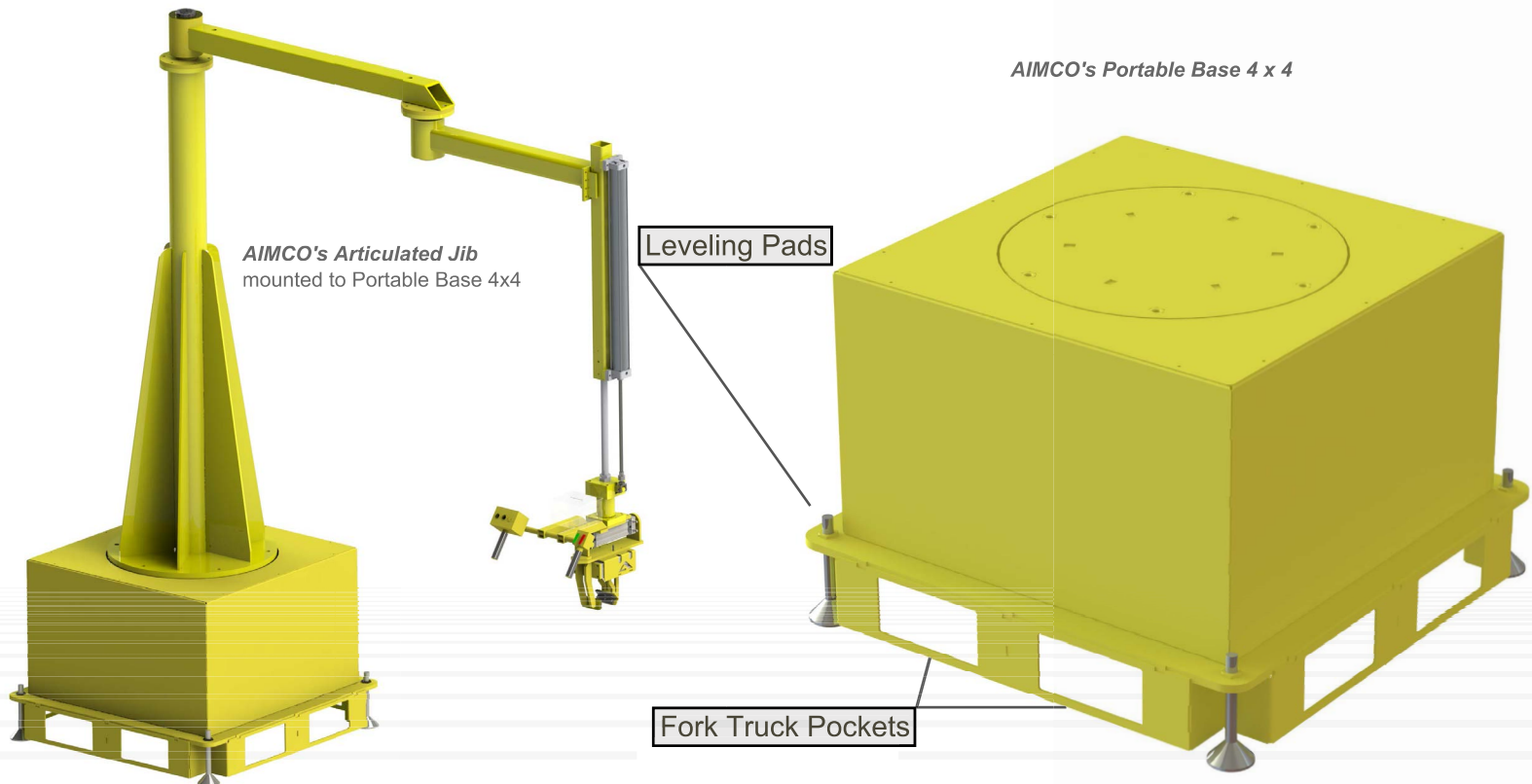

Torque Arm Size and Capacity



MODEL NO.	CAPACITY (LBS)	MAX MOMENT (FT-LBS)	WEIGHT (LBS)	A1 (IN)	A2 (IN)	B (IN)	C (IN)	ØD (IN)	S (IN)
-----------	-------------------	------------------------	-----------------	------------	------------	-----------	-----------	------------	-----------

AIMCO "300" Series

TA300-36	300	170	105	49.9	55.2	3.8	8	4.06	36
TA300-48	300	140	122	61.9	67.2	3.8	8	4.06	48
TA300-60	300	125	138	73.9	79.2	3.8	8	4.06	60

AIMCO "500" Series

TA500-36	500	280	144	52.9	58	3.5	9.3	4.06	36
TA500-48	500	270	166	64.9	70	3.5	9.3	4.06	48
TA500-60	500	250	189	76.9	82	3.5	9.3	4.06	60

AIMCO "1000" Series

TA1000-36	1000	825	206	55.3	67.2	10.3	11.6	4.06	36
TA1000-48	1000	755	235	67.3	79.2	10.3	11.6	4.06	48
TA1000-60	1000	625	264	52.9	91.2	10.3	11.6	4.06	60

*Vertical Stroke listed above is for reference only.
The scope of the application will determine
the exact needed stroke.

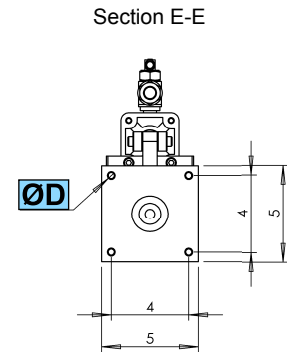
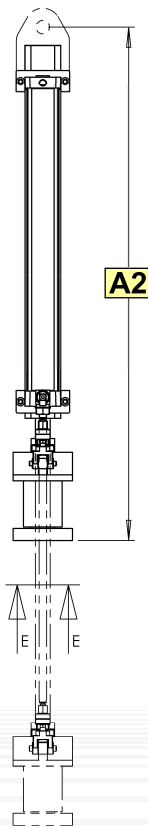
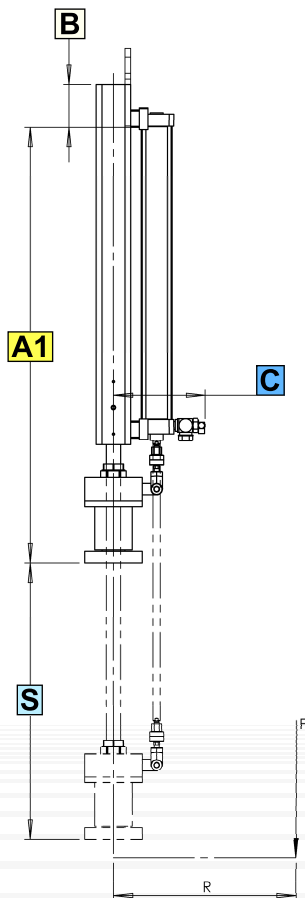

- R = Reach-in Dimension
- F = Force of Load Mass
- Moment = $R * F$
- S = Stroke
- A1 For Jib/ Platform Mount
- A2 Single Point Trolley Mount

How to Order: Series 'VAJ' AIMCO Vacuum Series Articulating Jib

VAJ ^{1.} 150-8 ^{2.} P - ^{3.} 1F - ^{4.} PM - ^{5.} PB - ^{6.} LH

1. CAPACITY (LBS.) / REACH	
150-8P-1F	150lb. at 8 feet
270-8P-2F	270lb. at 8 feet
125-10P-1F	125lb. at 10 feet
250-10P-2F	250lb. at 10 feet
100-12P-1F	100lb. at 12 feet
225-12P-2F	225lb. at 12 feet
70-15P-1F	70lb. at 15 feet
150-15P-2F	150lb. at 15 feet

2. JIB MOUNT TYPE	
P	Pedestal
C	Column
M	Machine
U	Underhung
MP24	H-Frame Platform 24
MP36	H-Frame Platform 36
MP48	H-Frame Platform 48

3. VACUUM PUMP SPECIFICATION	
-1F	Diameter of flow path = 1"
-2F	Diameter of flow path = 2"

4. STANDARD OPTION	
PM	Pump Mount

5. STANDARD OPTION	
PB	Portable Base

6. STANDARD OPTION	
LH	Low Headroom

AIMCO Vacuum Series Articulating Jib with 360° continuous rotation at two pivot joints. Each pivot joint is equipped with Timken tapered roller bearings, pregreased and sealed, designed to a 5:1 safety factor.

To Order, Please Specify: Series, Vacuum Pump, Radial Reach, Mount Type, and Standard Options.

Vacuum Lines: Internal and sealed from pedestal to end of arm. Custom pivot joints are outfitted with radial shaft seals and heavy duty o-rings to perform as a vacuum rotary union. The equivalent cross-sectional area of 1" or 2" diameter flow path is maintained throughout the jib arm; from the pedestal's inlet, to the end of arm outlet.

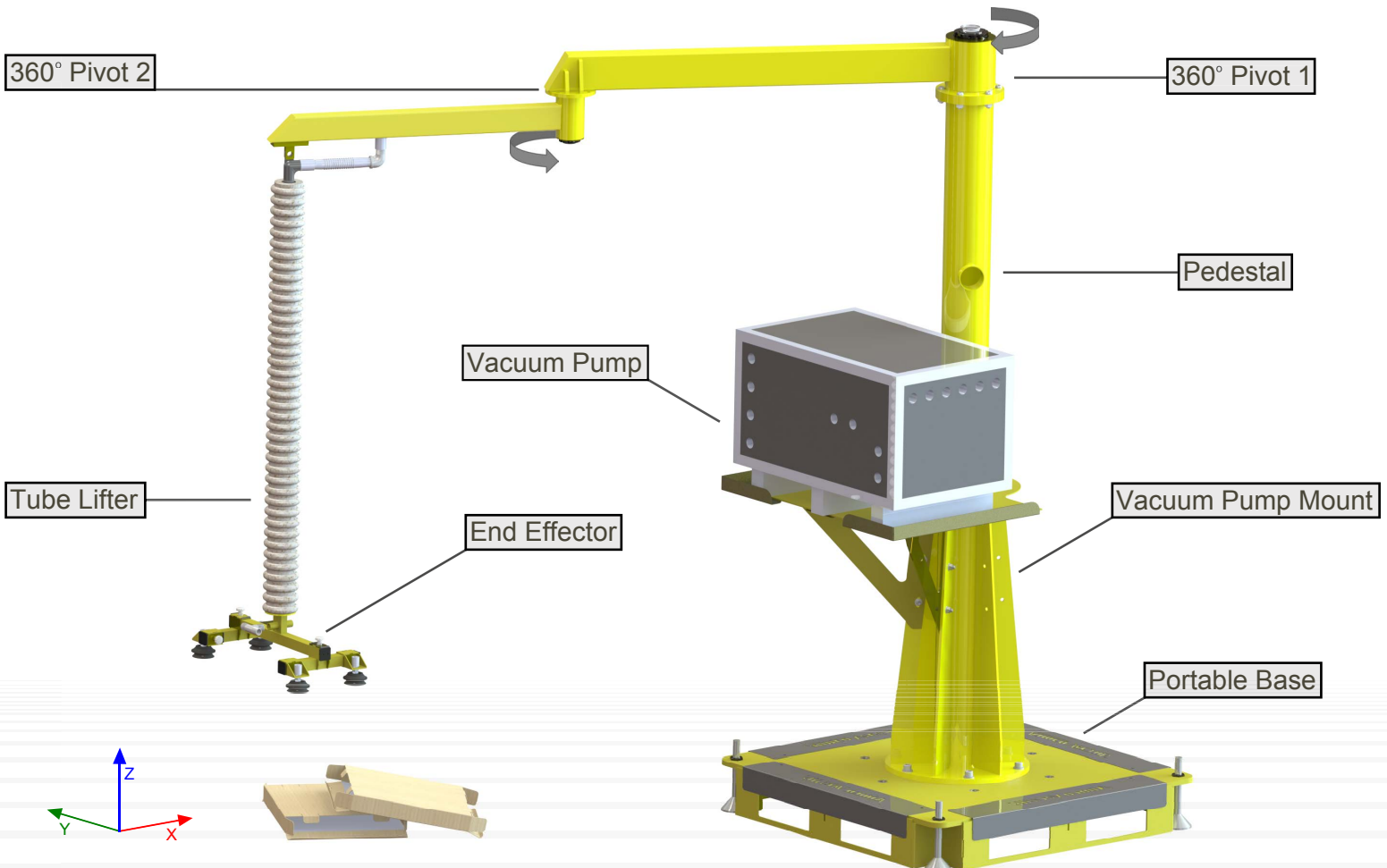

WIDTH(X) * DEPTH(Y) * HEIGHT(Z)

Order Code: VAJ150-8P-1F-PM-PB

How to Order: Series 'ACU' (Auto Clamp/ Unclamp End Effector)

1. CLAMPING COMPONENT TYPE	
VGN	Vacuum grab for non-porous & impermeable material
VGP	Vacuum grab for porous material (50 LBS. Max Capacity)
MAG	Magnet grab with an exposed face
SPC	Supplied (By Other) pneumatic clamping component
ACE	AIMCO Custom end effector (To be quoted)

2. END EFFECTOR CAPACITY (LBS.)	
1-80	VGP, VGN, & MAG
1-200	VGN & MAG only
1-500	ACE only (SPC to be determined)

3. CLAMPING COMPONENT QUANTITY	
1	1 Vacuum cup or air magnet, Z mount position only
2	2 Vacuum cups or air magnets
4	4 Vacuum cups or air magnets
8	8 Vacuum cups
16	16 Vacuum cups

ACU - ^{1.} VGN - ^{2.} 99 - ^{3.} 1 - ^{4.} Z - ^{5.} GF - ^{6.} M - ^{7.} 48 X 48

4. CLAMPING COMPONENT MOUNT POSITION	
Z	Fixed in-line with the z-axis
X	Adjustable along the x-axis
Y	Adjustable along the y-axis
XY	Adjustable along the x & y axes

5. LIFTING DEVICE CONTROLLER	
GF	GORBEL FORCE-SENSING-HUB
GL	GORBEL SLIDE HANDLE
KL	KONECRANES SLIDE HANDLE
AT	AIMCO THROTTLE CONTROLLER
SP	SUPPLIED (BY OTHER)

6. M	
See TABLE 1 For MINIMUM Part Dimensions depth X width	

7. MAXIMUM PART DEPTH X WIDTH (IN.)	
(0-48) X (0-48)	Made to order

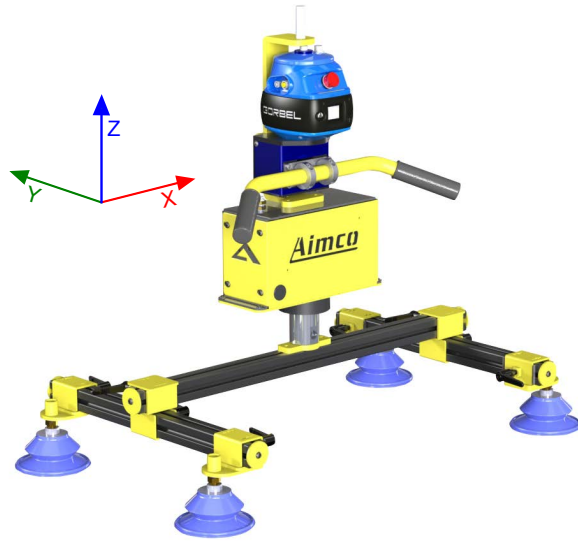

Order Code: ACU-VGN200-4XY-GF-M48X48

WIDTH(X) * DEPTH(Y) * HEIGHT(Z)

TABLE 1

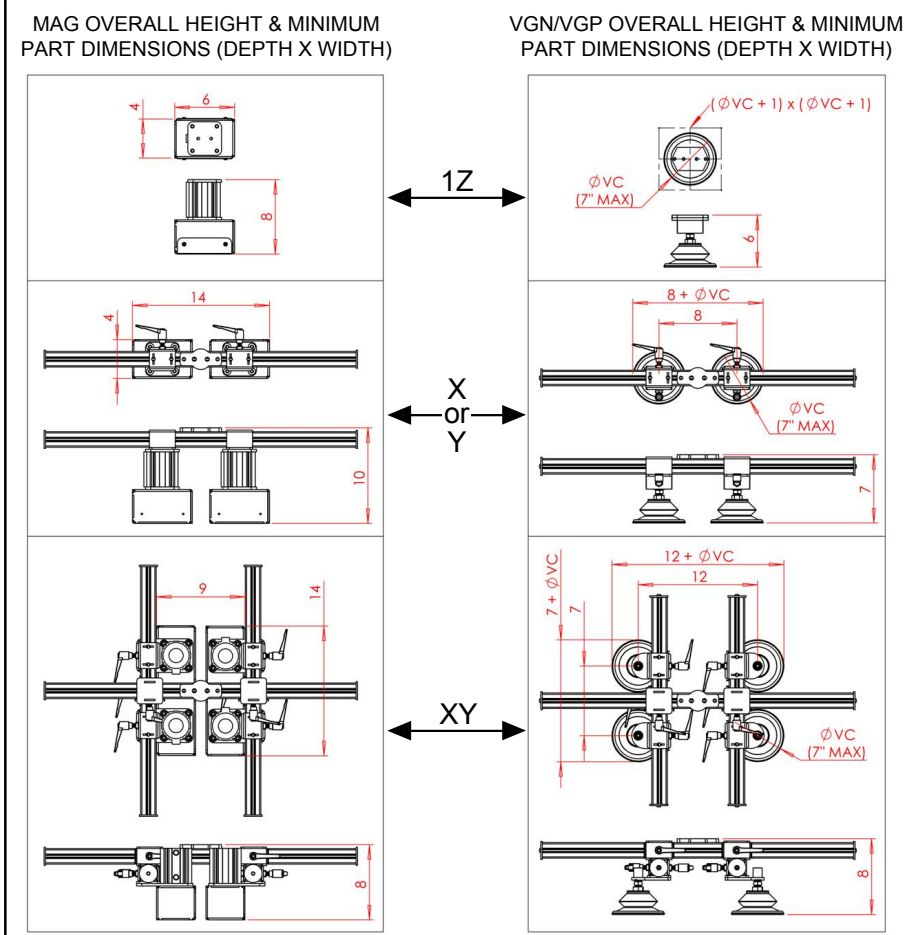
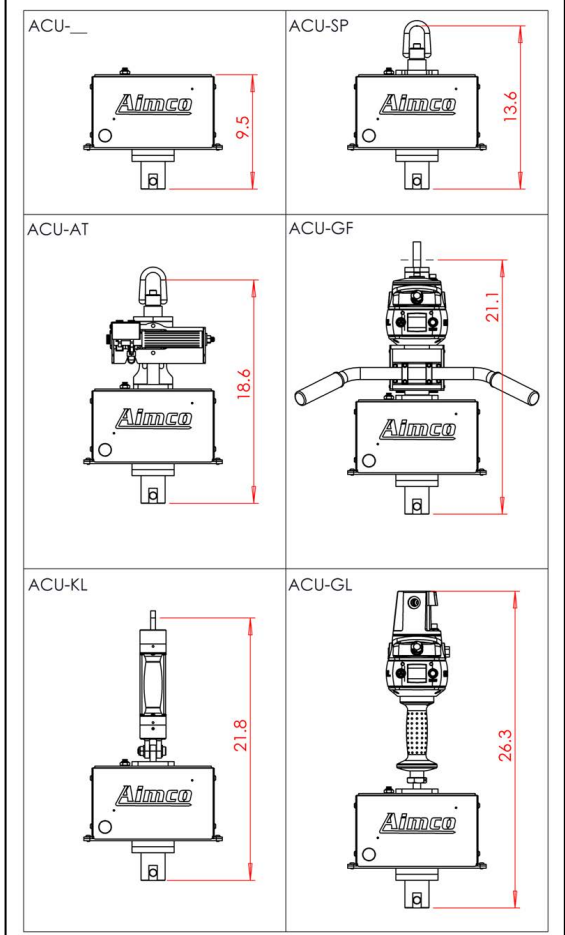
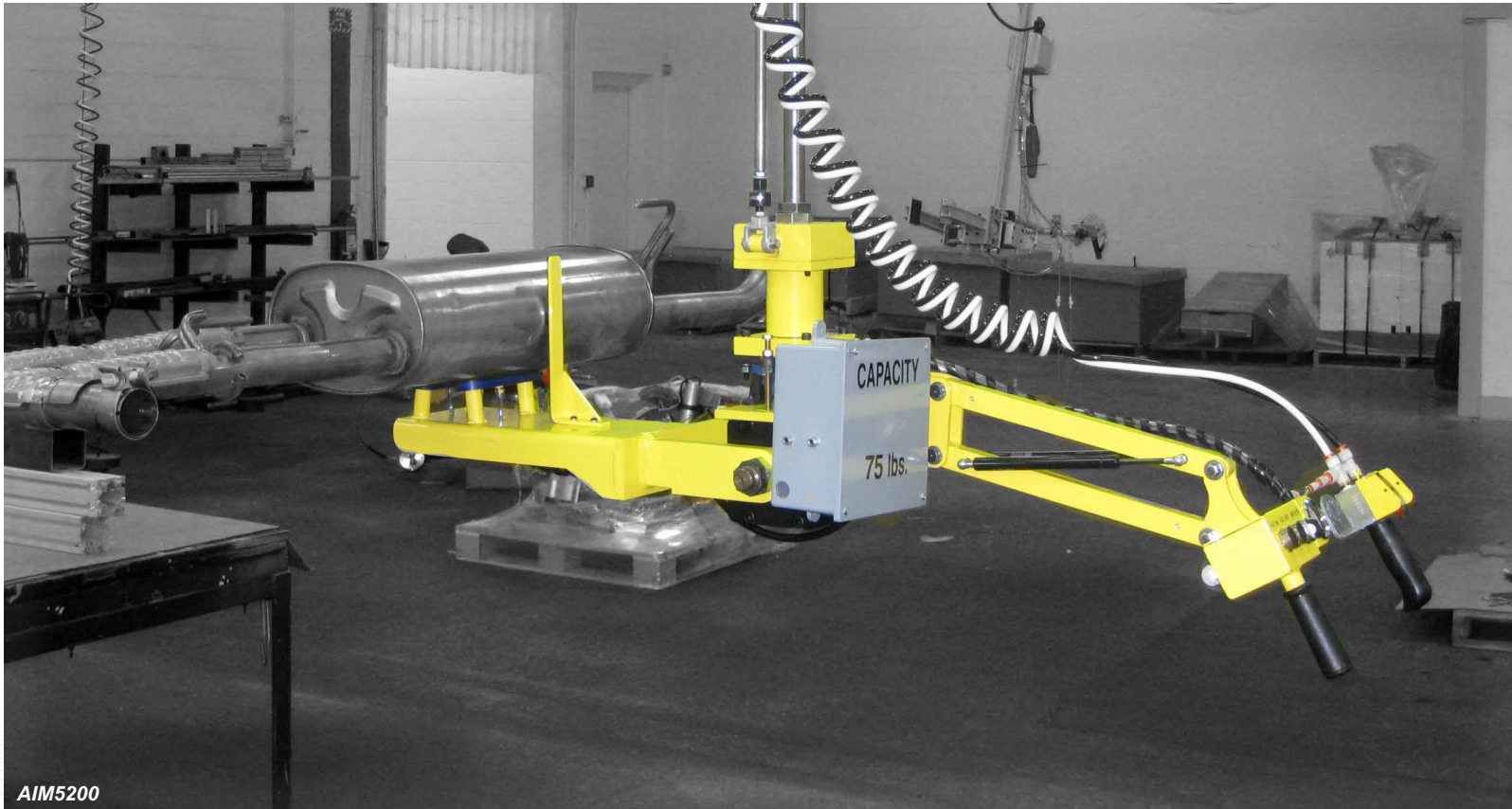
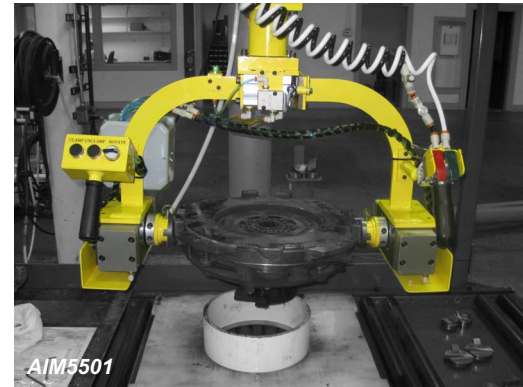

TABLE 2





203 Matzinger Road Toledo, OH 43612
Phone: (419) 478-4851 Fax: (419) 476-1324
www.AimcoManufacturing.com
Sales@AimcoManufacturing.com

Application Examples

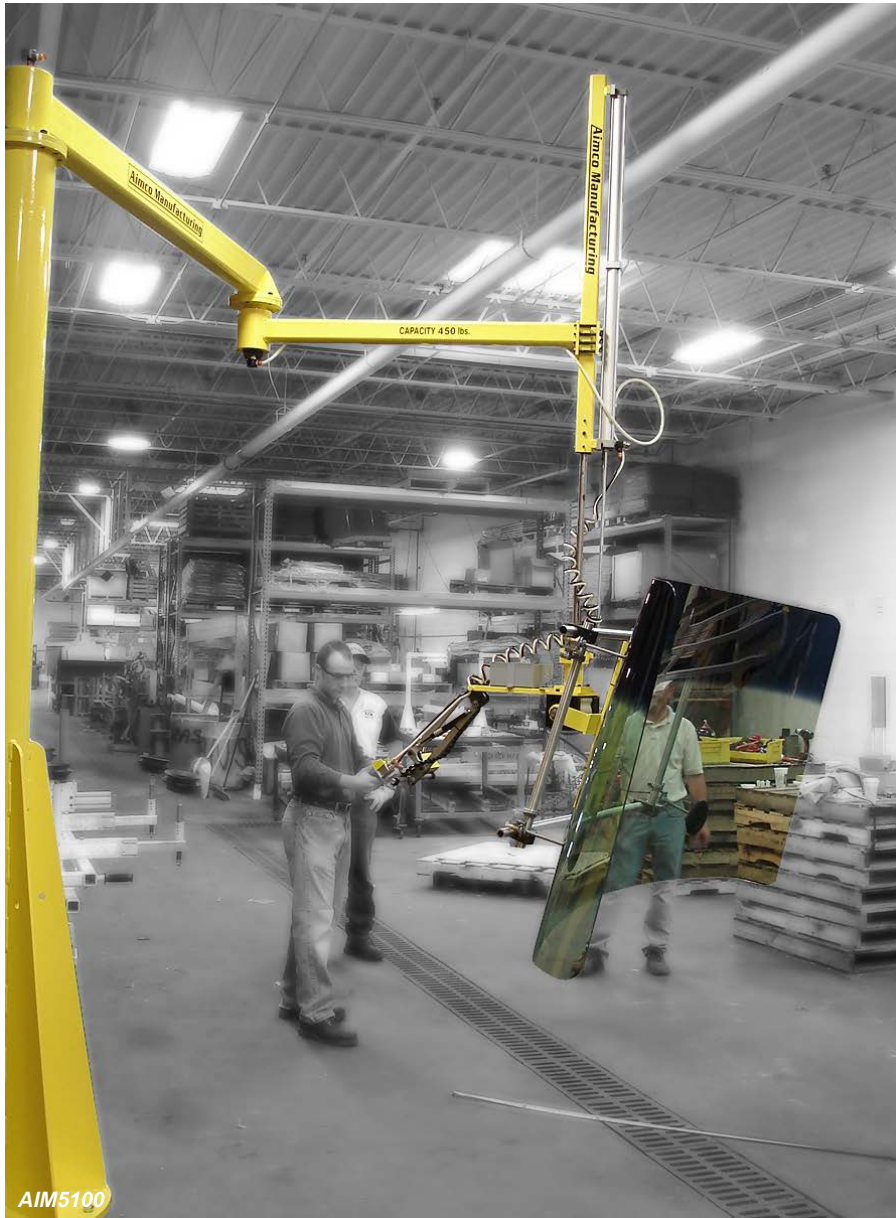

AIM5100

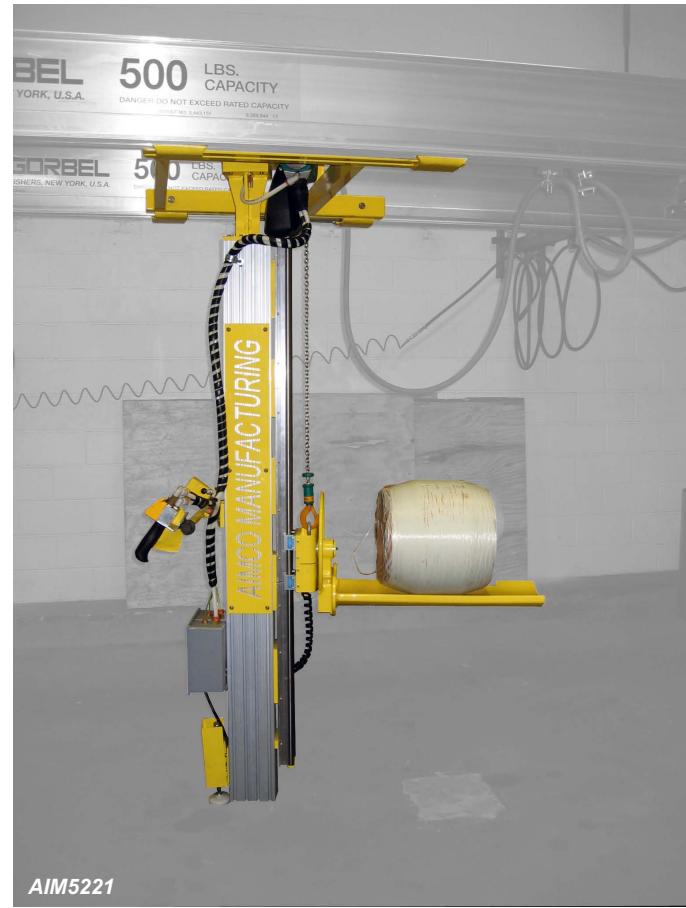

AIM5221

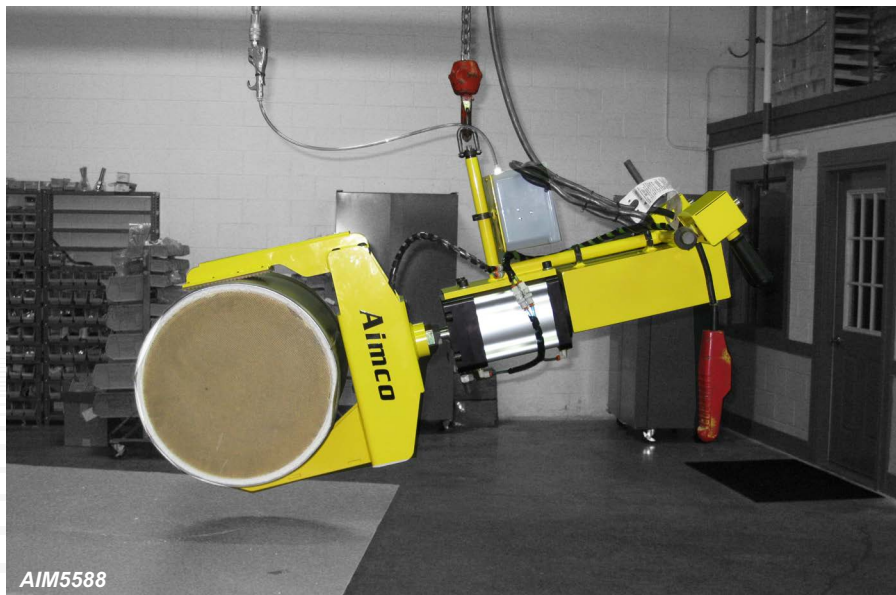

AIM5588



AIM4910



AIM6118

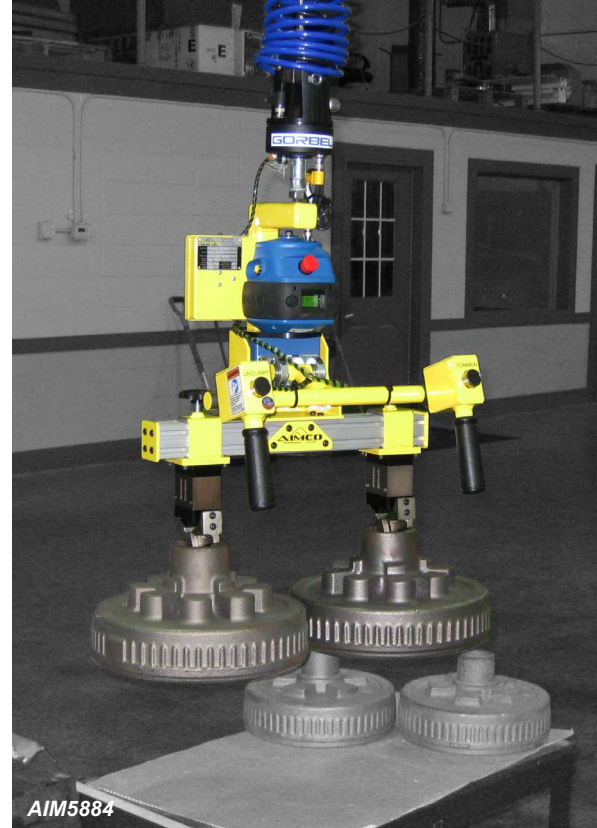

AIM5884



AIM4920

Application Examples

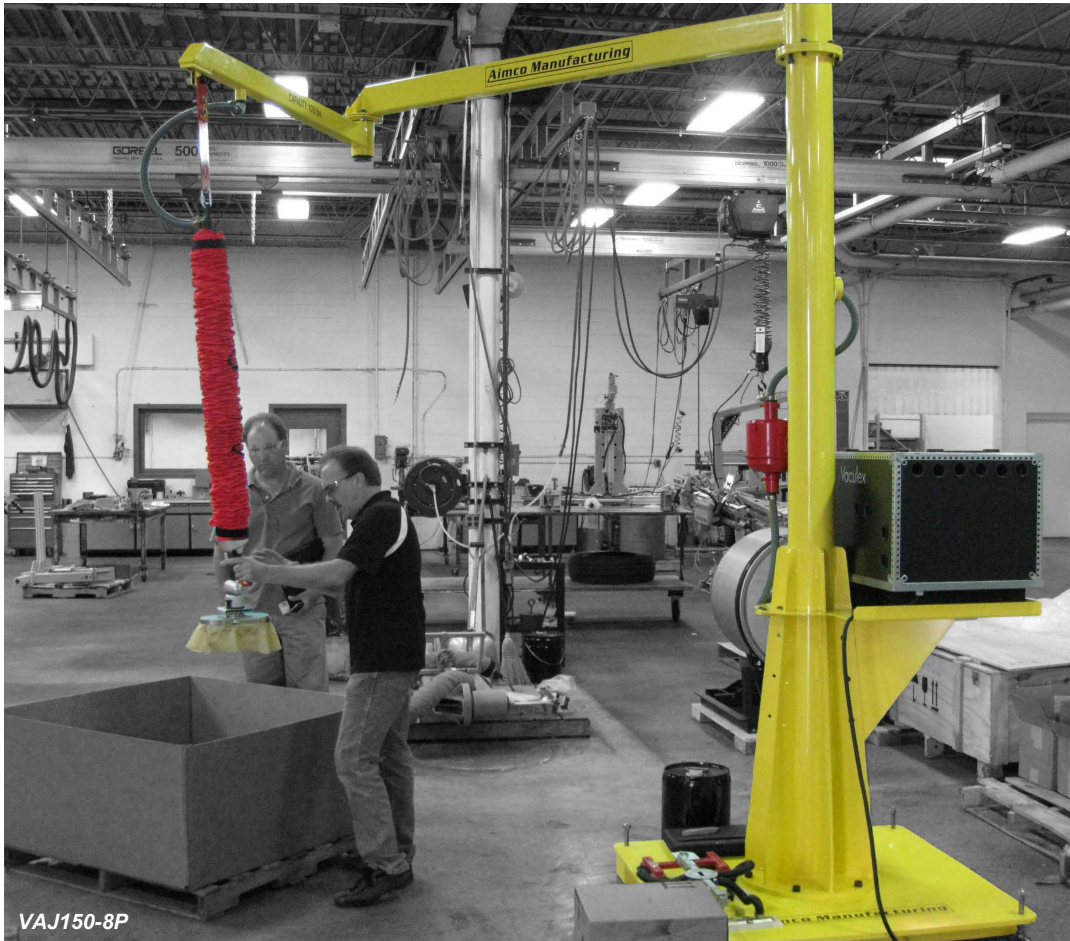

VAJ150-8P



AIM5752

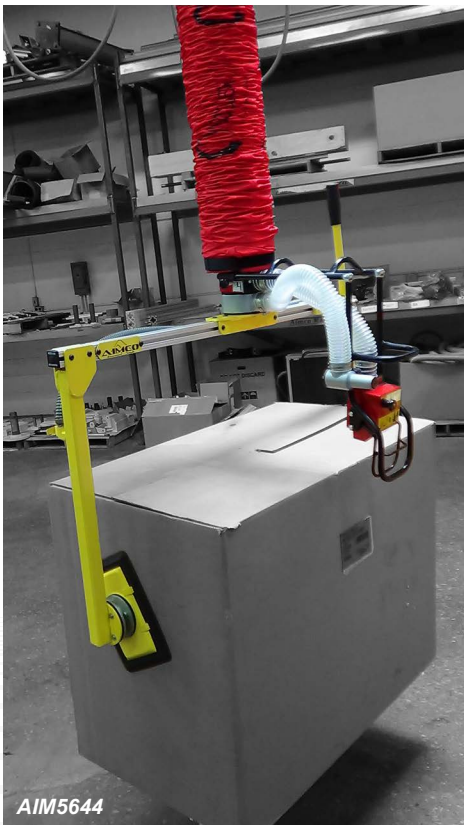

AIM5644



AIM4900

Distributed by:

Rev. 4/2015



SUSPENSION

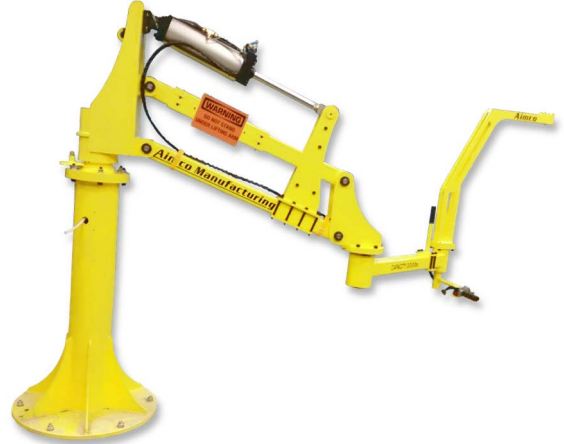

LIFTING



TOOLING

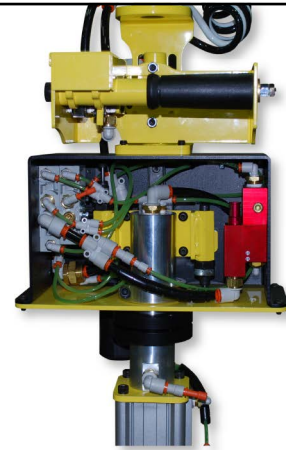

CONTROLS & SAFETIES



203 Matzinger Road Toledo, OH 43612
Phone: (419) 478-4851 Fax: (419) 476-1324
www.AimcoManufacturing.com
Sales@AimcoManufacturing.com